

#3 & #5 Preset Panning Rectangular



Series: Accessories Manufacturing Code: PPN01

Drawing 1/2 Scale – For Custom Size Drawing Contact Graham

Note: Sealant Not Shown On Details. Refer To General Installation Instructions.

Note: Pre-Set Panning Requires The Use Of Equal Leg Sill On Window
Some Pre-Set Panning Require The Use Of Mechanical Corner Keys For
Mitered Assembly. Reference Sheet PPN.CK For Representative Corner Detail.

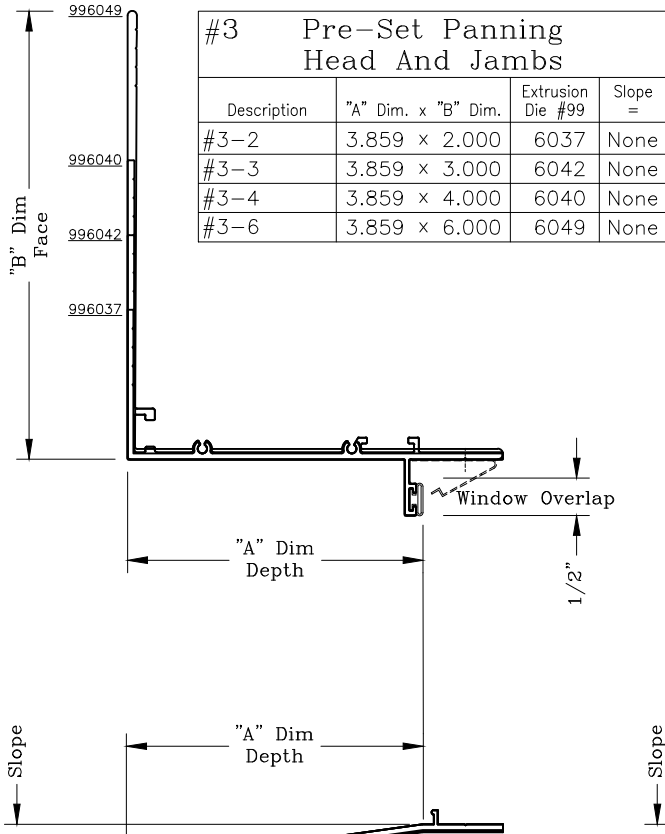

#3 Pre-Set Panning Head And Jambs			
Description	"A" Dim. x "B" Dim.	Extrusion Die #99	Slope =
#3-2	3.859 x 2.000	6037	None
#3-3	3.859 x 3.000	6042	None
#3-4	3.859 x 4.000	6040	None
#3-6	3.859 x 6.000	6049	None

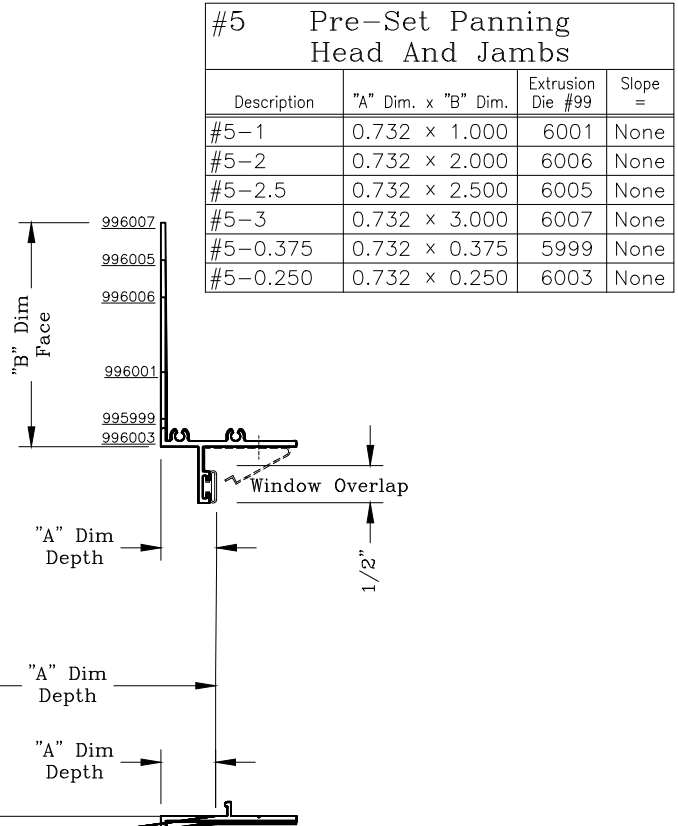

#5 Pre-Set Panning Head And Jambs			
Description	"A" Dim. x "B" Dim.	Extrusion Die #99	Slope =
#5-1	0.732 x 1.000	6001	None
#5-2	0.732 x 2.000	6006	None
#5-2.5	0.732 x 2.500	6005	None
#5-3	0.732 x 3.000	6007	None
#5-0.375	0.732 x 0.375	5999	None
#5-0.250	0.732 x 0.250	6003	None

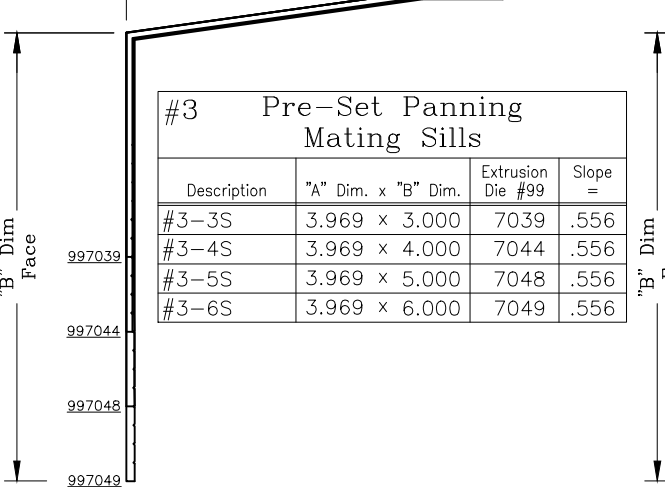

#3 Pre-Set Panning Mating Sills			
Description	"A" Dim. x "B" Dim.	Extrusion Die #99	Slope =
#3-3S	3.969 x 3.000	7039	.556
#3-4S	3.969 x 4.000	7044	.556
#3-5S	3.969 x 5.000	7048	.556
#3-6S	3.969 x 6.000	7049	.556

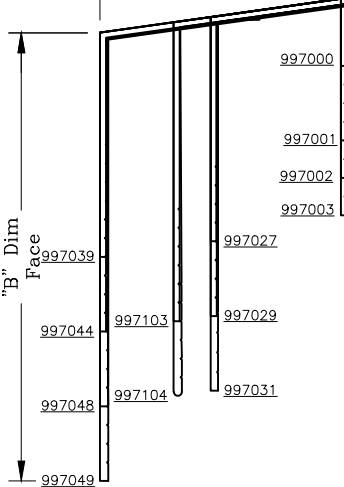

#5 Pre-Set Panning Mating Sills			
Description	"A" Dim. x "B" Dim.	Extrusion Die #99	Slope =
#5-1S	0.750 x 1.000	7000	NONE
#5-2S	0.750 x 2.000	7001	NONE
#5-2.5S	0.750 x 2.500	7002	NONE
#5-3S	0.750 x 3.000	7003	NONE
#8-3S	2.488 x 3.000	7027	.348
#8-4S	2.488 x 4.000	7029	.348
#8-5S	2.488 x 5.000	7031	.348
#3-3S	3.969 x 3.000	7039	.556
#3-4S	3.969 x 4.000	7044	.556
#3-5S	3.969 x 5.000	7048	.556
#3-6S	3.969 x 6.000	7049	.556
DEL-4S	2.983 x 4.000	7103	.417
DEL-5S	2.983 x 5.000	7104	.417

Graham Architectural Products reserves the right to change, add, cancel, remove or otherwise modify the details illustrated without prior notice.

1551 Mt. Rose Avenue, York, Pennsylvania 17403-2909 717.849.8100 Toll Free: 800/755-6274

0624 - PPN.01

Web Site: www.grahamwindows.com

#8 & #10 Preset Panning Rectangular



Series: Accessories Manufacturing Code: PPN02

Drawing 1/2 Scale – For Custom Size Drawing Contact Graham

Note: Sealant Not Shown On Details. Refer To General Installation Instructions.

Note: Pre-Set Panning Requires The Use Of Equal Leg Sill On Window

Some Pre-Set Panning Require The Use Of Mechanical Corner Keys For Mitered Assembly. Reference Sheet PPN.CK For Representative Corner Detail.

#8 Pre-Set Panning Head And Jamb			
Description	"A" Dim. x "B" Dim.	Extrusion Die #99	Slope =
#8-3	2.473 x 3.000	6027	None
#8-4	2.473 x 4.000	6029	None

#10 Pre-Set Panning Head And Jamb			
Description	"A" Dim. x "B" Dim.	Extrusion Die #99	Slope =
#10-2	1.696 x 2.000	6013	None
#10-3	1.696 x 3.000	6015	None
#10-4	1.696 x 4.000	6017	None

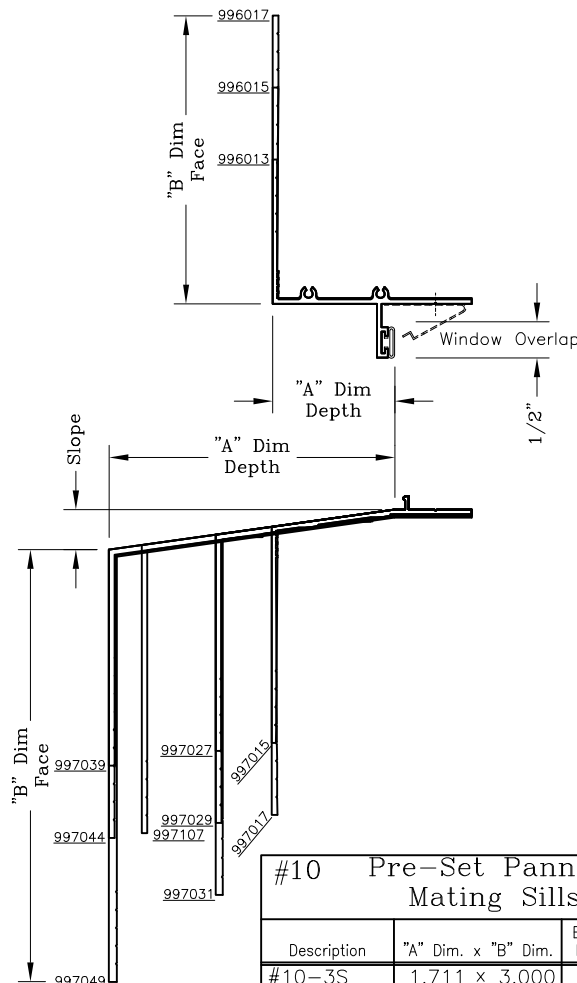
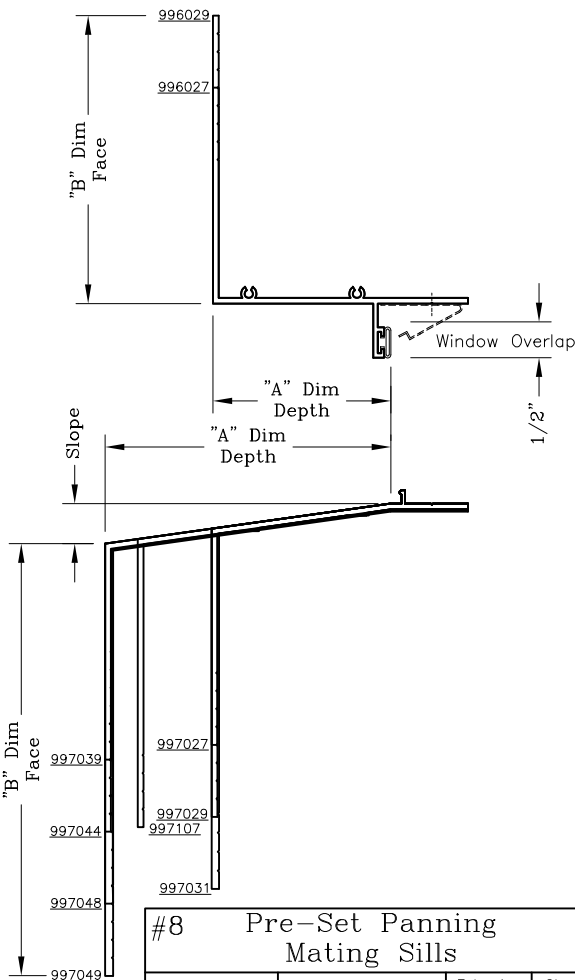

#8 Pre-Set Panning Mating Sills			
Description	"A" Dim. x "B" Dim.	Extrusion Die #99	Slope =
#8-3S	2.488 x 3.000	7027	.348
#8-4S	2.488 x 4.000	7029	.348
#8-5S	2.488 x 5.000	7031	.348
#3-3S	3.969 x 3.000	7039	.556
#3-4S	3.969 x 4.000	7044	.556
#3-5S	3.969 x 5.000	7048	.556
#3-6S	3.969 x 6.000	7049	.556
3.5x4.0	3.500 x 4.000	7107	.493

#10 Pre-Set Panning Mating Sills			
Description	"A" Dim. x "B" Dim.	Extrusion Die #99	Slope =
#10-3S	1.711 x 3.000	7015	.239
#10-4S	1.711 x 4.000	7017	.239
#8-3S	2.488 x 3.000	7027	.348
#8-4S	2.488 x 4.000	7029	.348
#8-5S	2.488 x 5.000	7031	.348
#3-3S	3.969 x 3.000	7039	.556
#3-4S	3.969 x 4.000	7044	.556
#3-6S	3.969 x 6.000	7049	.556
3.5x4.0	3.500 x 4.000	7107	.493

Graham Architectural Products reserves the right to change, add, cancel, remove or otherwise modify the details illustrated without prior notice.

1551 Mt. Rose Avenue, York, Pennsylvania 17403-2909 717.849.8100 Toll Free: 800/755-6274

0223 - PPN.02

Web Site: www.grahamwindows.com

Preset Panning Contoured



Series: Accessories Manufacturing Code: PPN03

Drawing 1/2 Scale – For Custom Size Drawing Contact Graham

Note: Sealant Not Shown On Details. Refer To General Installation Instructions.

Note: Pre-Set Panning Requires The Use Of Equal Leg Sill On Window
Some Pre-Set Panning Require The Use Of Mechanical Corner Keys For
Mitered Assembly. Reference Sheet PPN.CK For Representative Corner Detail.

William Penn Pre-Set Panning Head And Jamb			
Description	"A" Dim. x "B" Dim.	Extrusion Die #99	Slope =
William Penn #3	2.944 x 3.000	6053	None

Delaware/Delaware #2/Boylan Pre-Set Panning Head And Jamb			
Description	"A" Dim. x "B" Dim.	Extrusion Die #99	Slope =
Delaware	2.945 x 3.750	6101	None
Delaware #2	2.945 x 3.188	6183	
Boylan	2.945 x 5.500	6102	None

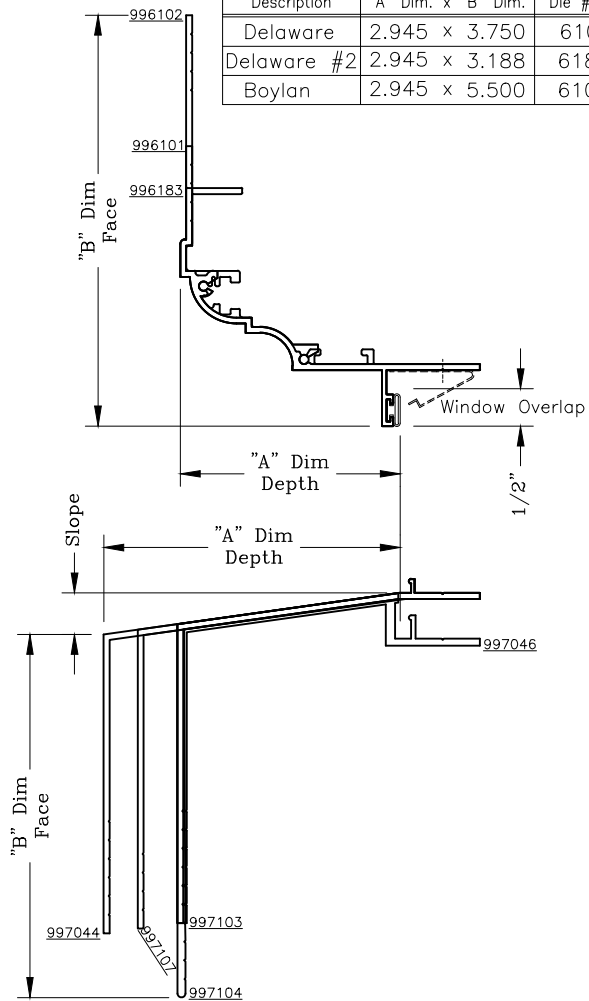
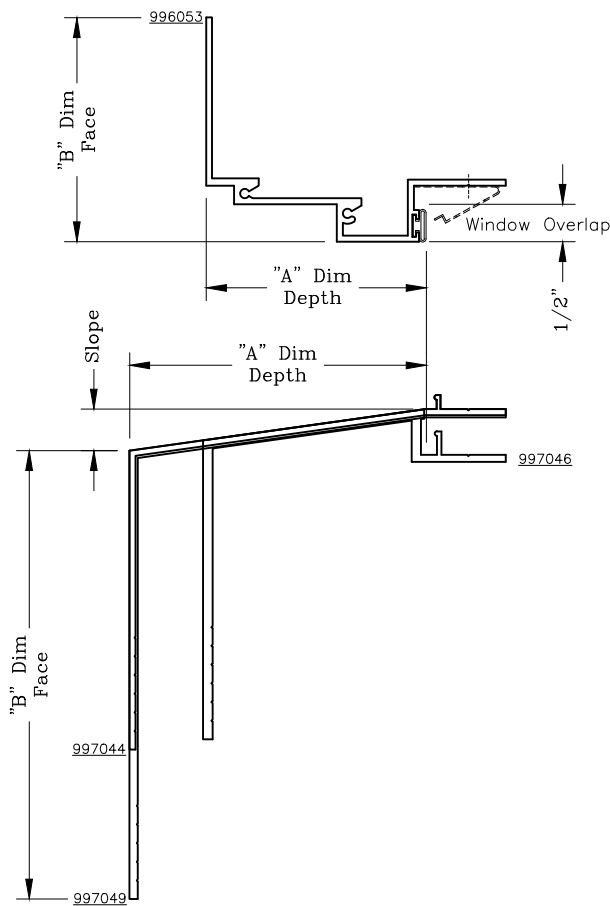

William Penn Pre-Set Panning Mating Sill			
Description	"A" Dim. x "B" Dim.	Extrusion Die #99	Slope =
#3-4S	3.969 x 4.000	7044	.556
#3-6S	3.959 x 6.000	7049	.556
Del.-4S	2.984 x 4.000	7046	.415

Delaware/Boylan Pre-Set Panning Mating Sill			
Description	"A" Dim. x "B" Dim.	Extrusion Die #99	Slope =
Del.-4S	2.984 x 4.00	7103	.415
Del.-5S	2.984 x 5.00	7104	.415
Del.-4S	2.984 x 4.00	7046	.415
#3-4S	3.969 x 4.00	7044	.556
3.5x4.0	3.500 x 4.00	7107	.493

Graham Architectural Products reserves the right to change, add, cancel, remove or otherwise modify the details illustrated without prior notice.

1551 Mt. Rose Avenue, York, Pennsylvania 17403-2909 717.849.8100 Toll Free: 800/755-6274

0823 – PPN.03

Web Site: www.grahamwindows.com

Preset Panning Contoured



Series: Accessories Manufacturing Code: PPN04

Drawing 1/2 Scale – For Custom Size Drawing Contact Graham

Note: Sealant Not Shown On Details. Refer To General Installation Instructions.

Note: Pre-Set Panning Requires The Use Of Equal Leg Sill On Window
Some Pre-Set Panning Require The Use Of Mechanical Corner Keys For
Mitered Assembly. Reference Sheet PPN.CK For Representative Corner Detail.

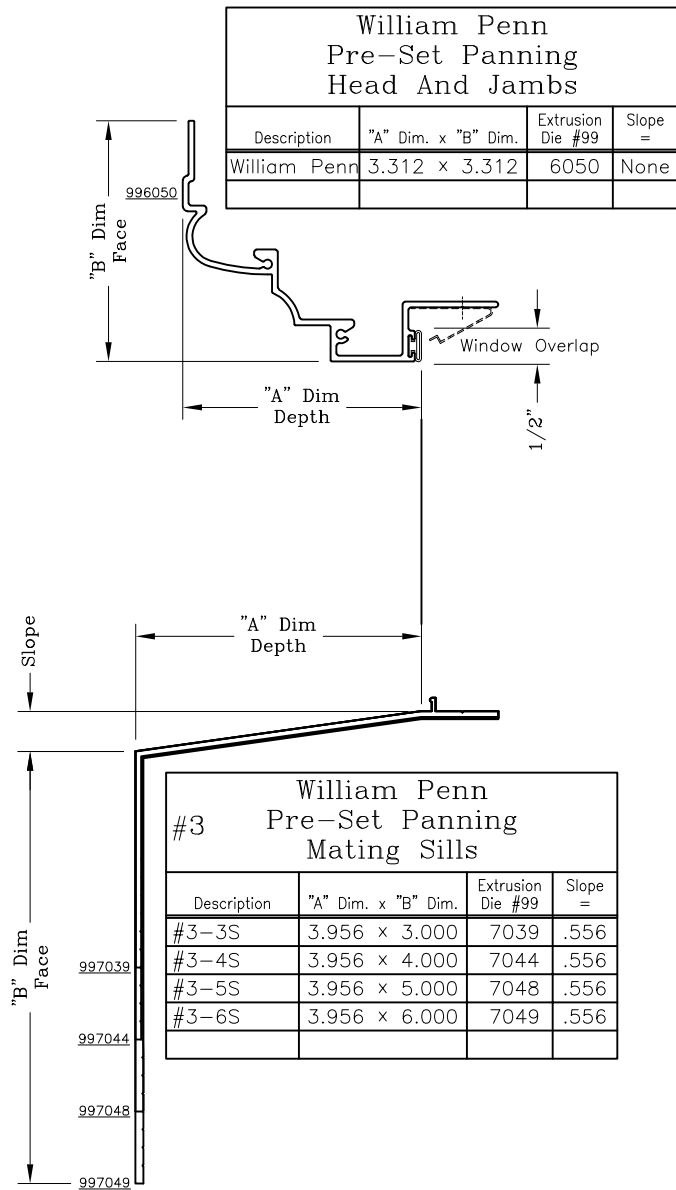
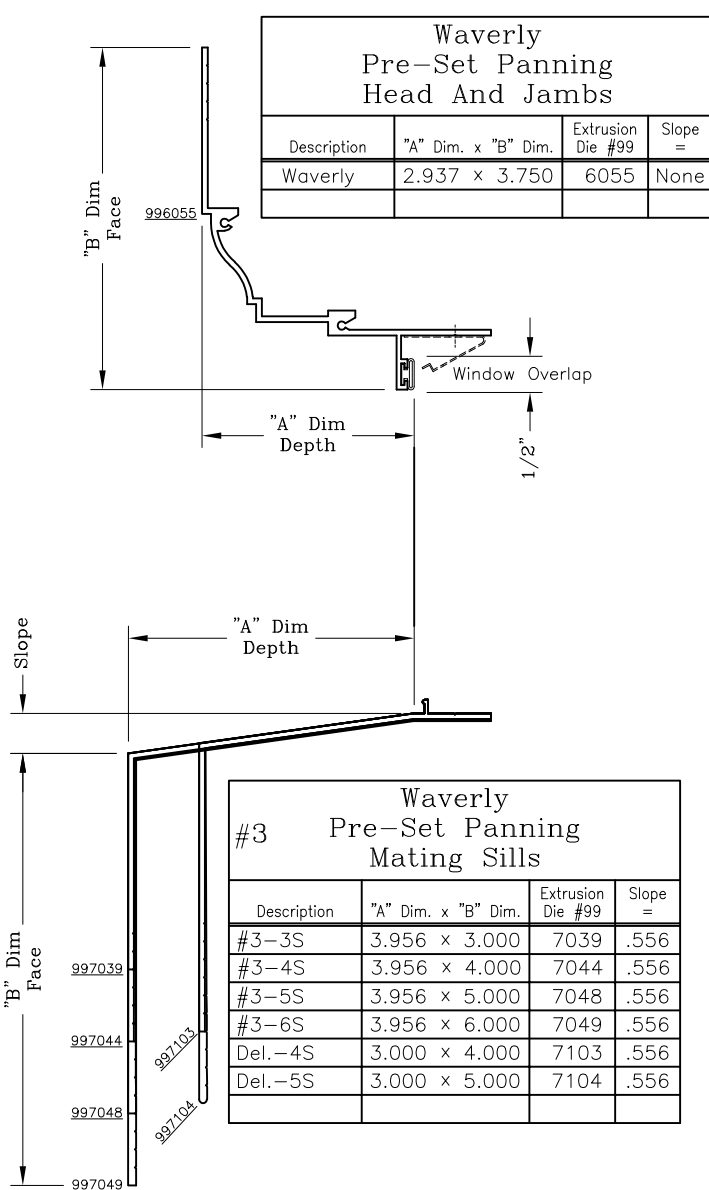

Graham Architectural Products reserves the right to change, add, cancel, remove or otherwise modify the details illustrated without prior notice.

1551 Mt. Rose Avenue, York, Pennsylvania 17403-2909 717.849.8100 Toll Free: 800/755-6274

0223 – PPN.04

Web Site: www.grahamwindows.com

Preset Contoured Panning Contoured



Series: Accessories Manufacturing Code: PPN05

Drawing 1/2 Scale – For Custom Size Drawing Contact Graham

Note: Sealant Not Shown On Details. Refer To General Installation Instructions.

Note: Pre-Set Panning Requires The Use Of Equal Leg Sill On Window
Some Pre-Set Panning Require The Use Of Mechanical Corner Keys For
Mitered Assembly. Reference Sheet PPN.CK For Representative Corner Detail.

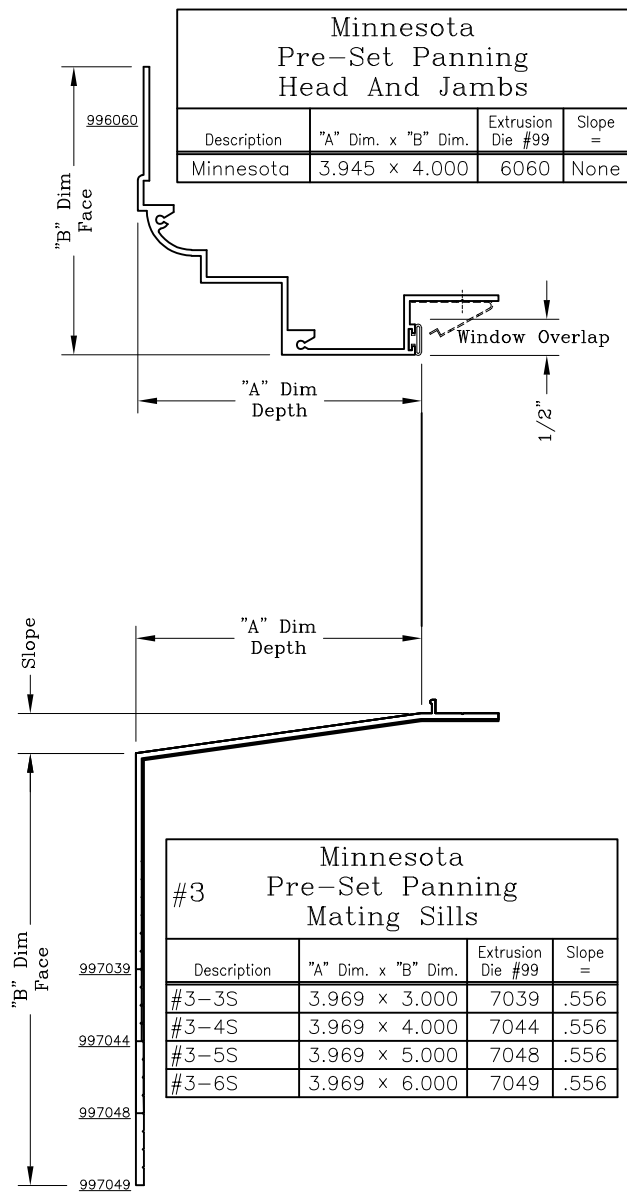
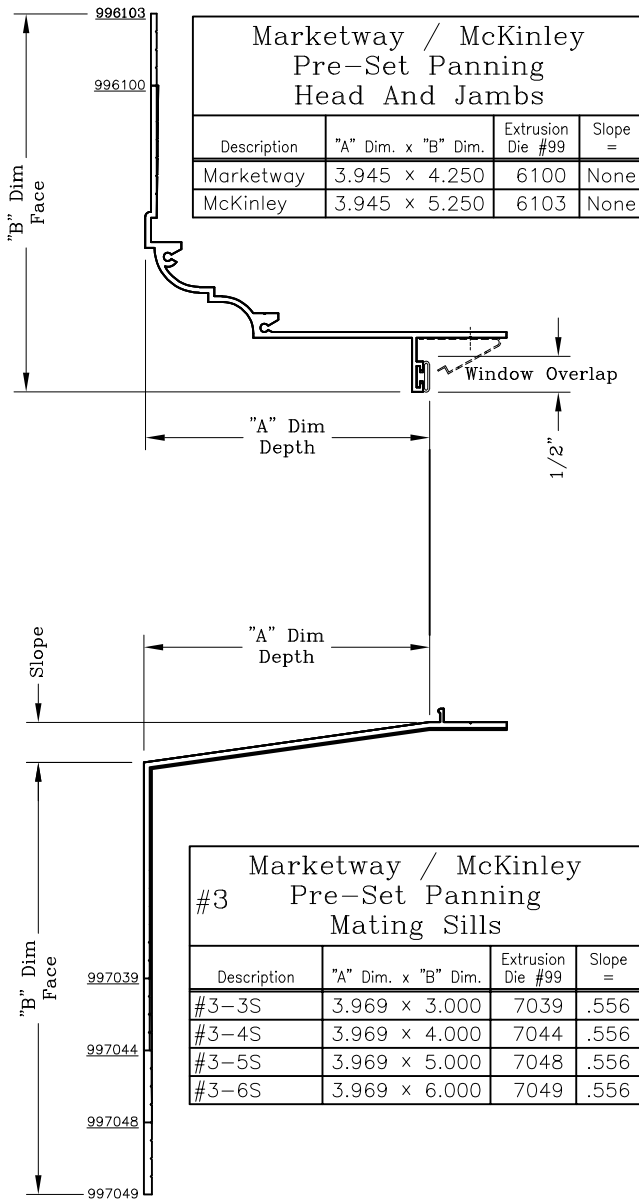

Graham Architectural Products reserves the right to change, add, cancel, remove or otherwise modify the details illustrated without prior notice.

1551 Mt. Rose Avenue, York, Pennsylvania 17403-2909 717.849.8100 Toll Free: 800/755-6274

0223 - PPN.05

Web Site: www.grahamwindows.com

Preset Panning Contoured



Series: Accessories Manufacturing Code: PPN06

Drawing 1/2 Scale – For Custom Size Drawing Contact Graham

Note: Sealant Not Shown On Details. Refer To General Installation Instructions.

Note: Pre-Set Panning Requires The Use Of Equal Leg Sill On Window
Some Pre-Set Panning Require The Use Of Mechanical Corner Keys For
Mitered Assembly. Reference Sheet PPN.CK For Representative Corner Detail.

Snead #1 Pre-Set Panning Head And Jamb			
Description	"A" Dim. x "B" Dim.	Extrusion Die #99	Slope
Snead #1	2.180 x 2.250	9727	None

Charlestown Pre-Set Panning Head And Jamb			
Description	"A" Dim. x "B" Dim.	Extrusion Die #99	Slope =
Charlestown	2.888 x 2.500	6051	None

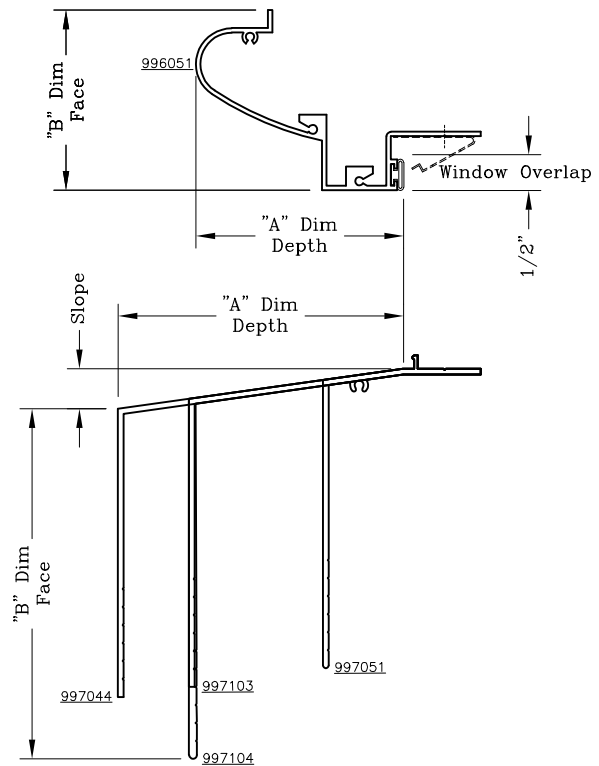
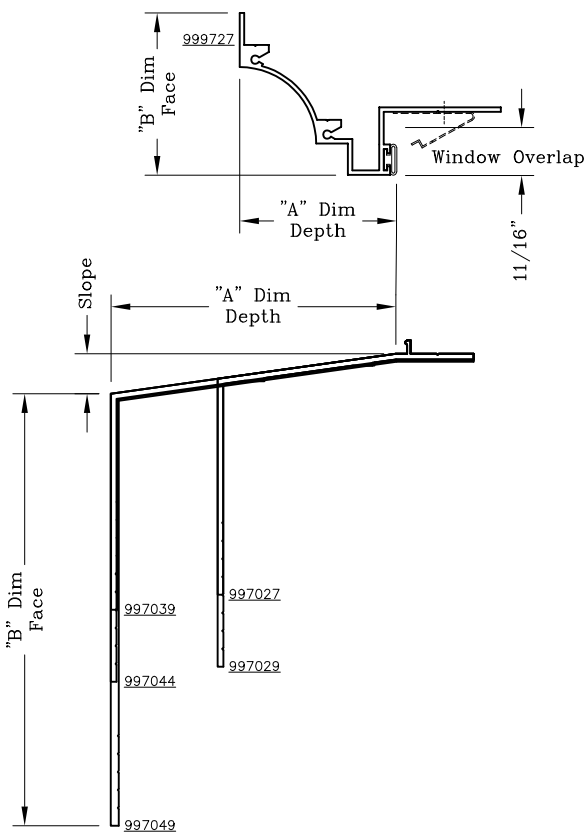

Snead #1 Pre-Set Panning Mating Sill			
Description	"A" Dim. x "B" Dim.	Extrusion Die #99	Slope =
#8-3S	2.488 x 3.000	7027	.348
#8-4S	2.488 x 4.000	7029	.348
#3-3S	3.969 x 3.000	7039	.556
#3-4S	3.969 x 4.000	7044	.556
#3-6S	3.969 x 6.000	7049	.556

Charlestown Pre-Set Panning Mating Sill			
Description	"A" Dim. x "B" Dim.	Extrusion Die #99	Slope =
Del-4S	2.984 x 4.000	7103	.415
Del-5S	2.984 x 5.000	7104	.415
#3-4S	3.969 x 4.000	7044	.559
Charlestown	1.125 x 4.000	7051	.156

Graham Architectural Products reserves the right to change, add, cancel, remove or otherwise modify the details illustrated without prior notice.

1551 Mt. Rose Avenue, York, Pennsylvania 17403-2909 717.849.8100 Toll Free: 800/755-6274

0223 - PPN.06

Web Site: www.grahamwindows.com

Preset Panning Contoured



Series: Accessories Manufacturing Code: PPN07

Drawing 3/8 Scale – For Custom Size Drawing Contact Graham

Note: Sealant Not Shown On Details. Refer To General Installation Instructions.

Note: Pre-Set Panning Requires The Use Of Equal Leg Sill On Window
Some Pre-Set Panning Require The Use Of Mechanical Corner Keys For
Mitered Assembly. Reference Sheet PPN.CK For Representative Corner Detail.

Cotton Mill Pre-Set Panning Head And Jambs			
Description	"A" Dim. x "B" Dim.	Extrusion Die #99	Slope =
Cotton Mill	1.691 x 3.25	6061	None

Custom Pre-Set Panning Head And Jambs			
Description	"A" Dim. x "B" Dim.	Extrusion Die #99	Slope =
Custom	1.187 x 2.000	6014	None

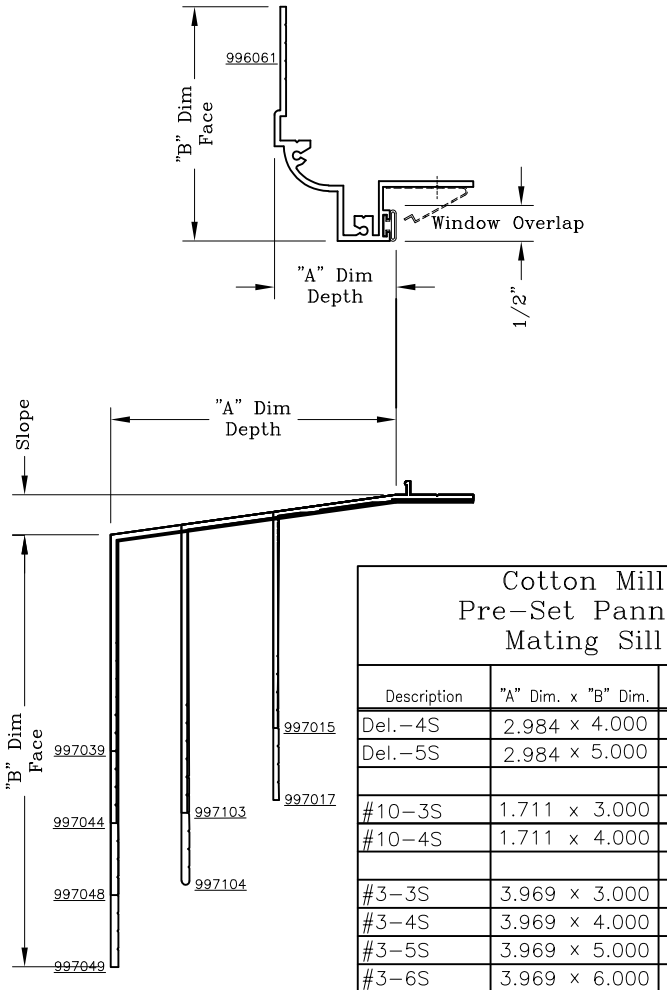

Cotton Mill Pre-Set Panning Mating Sill			
Description	"A" Dim. x "B" Dim.	Extrusion Die #99	Slope =
Del.-4S	2.984 x 4.000	7103	.415
Del.-5S	2.984 x 5.000	7104	.415
#10-3S	1.711 x 3.000	7015	.239
#10-4S	1.711 x 4.000	7017	.239
#3-3S	3.969 x 3.000	7039	.556
#3-4S	3.969 x 4.000	7044	.556
#3-5S	3.969 x 5.000	7048	.556
#3-6S	3.969 x 6.000	7049	.556

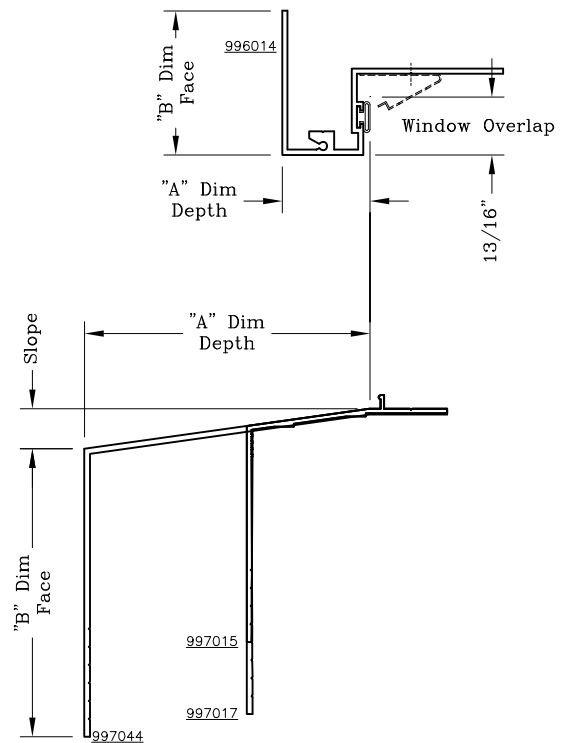

Custom Pre-Set Panning Mating Sill			
Description	"A" Dim. x "B" Dim.	Extrusion Die #99	Slope =
#10-3S	1.711 x 3.000	7015	.239
#10-4S	1.711 x 4.000	7017	.239
#3-4S	3.969 x 4.000	7044	.556

Graham Architectural Products reserves the right to change, add, cancel, remove or otherwise modify the details illustrated without prior notice.

1551 Mt. Rose Avenue, York, Pennsylvania 17403-2909 717.849.8100 Toll Free: 800/755-6274

0223 - PPN.07

Web Site: www.grahamwindows.com

Preset Panning Contoured



Series: Accessories Manufacturing Code: PPN08

Drawing 1/2 Scale – For Custom Size Drawing Contact Graham

Note: Sealant Not Shown On Details. Refer To General Installation Instructions.

Note: Pre-Set Panning Requires The Use Of Equal Leg Sill On Window
Some Pre-Set Panning Require The Use Of Mechanical Corner Keys For
Mitered Assembly. Reference Sheet PPN.CK For Representative Corner Detail.

Pre-Set Panning Head And Jambs			
Description	"A" Dim. x "B" Dim.	Extrusion P/N	Slope
60 Beach	2.192 x 2.000	857097	

Pre-Set Panning Head And Jambs			
Description	"A" Dim. x "B" Dim.	Extrusion P/N	Slope
Lafayette	3.030 x 1.562	851003	

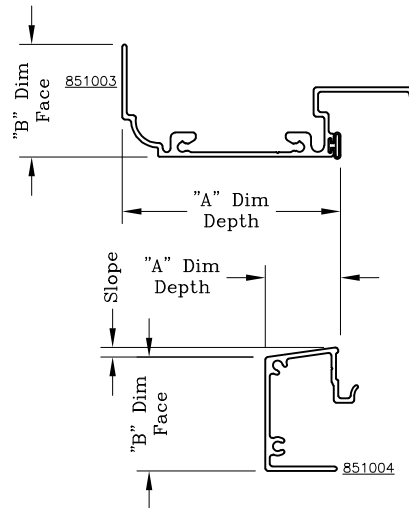
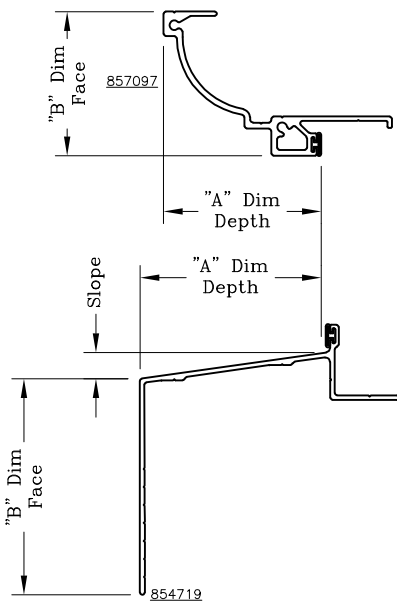

Pre-Set Panning Sill			
Description	"A" Dim. x "B" Dim.	Extrusion P/N	Slope
60 Beach	2.517 x 3.000	857097	.375

Pre-Set Panning Sill			
Description	"A" Dim. x "B" Dim.	Extrusion P/N	Slope
Lafayette	1.044 x 1.575	851004	.137

#8 Preset Panning Rectangular



Series: Accessories Manufacturing Code: PPN09

Drawing 1/2 Scale – For Custom Size Drawing Contact Graham

Note: Sealant Not Shown On Details. Refer To General Installation Instructions.

Note: Pre-Set Panning Requires The Use Of Equal Leg Sill On Window

Some Pre-Set Panning Require The Use Of Mechanical Corner Keys For Mitered Assembly. Reference Sheet PPN.CK For Representative Corner Detail.

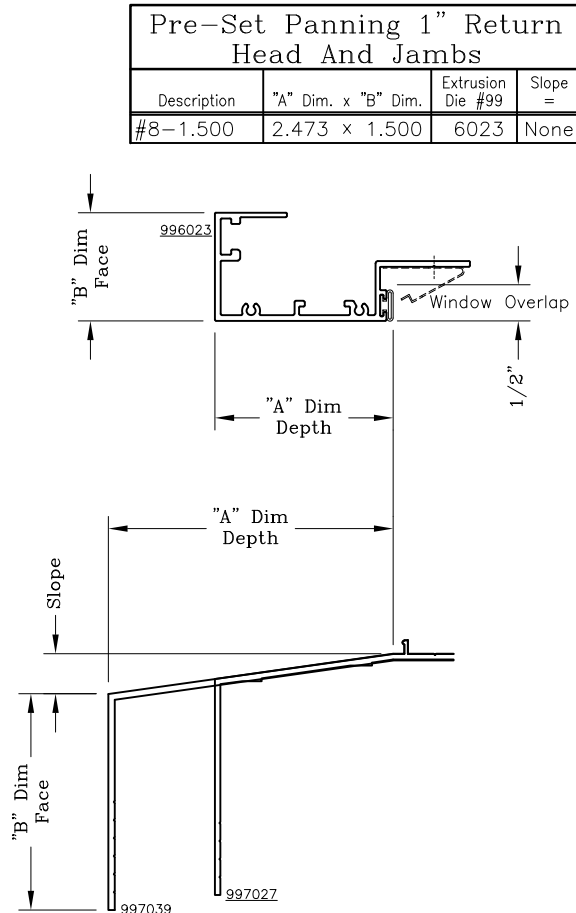
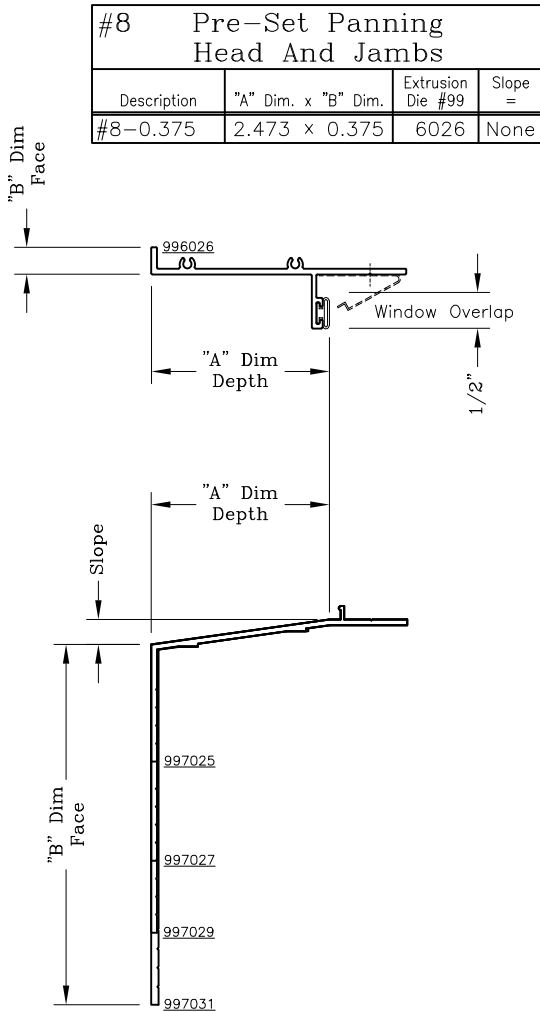

#8 Pre-Set Panning Mating Sills			
Description	"A" Dim. x "B" Dim.	Extrusion Die #99	Slope =
#8-3S	2.488 x 3.000	7027	.348
#8-4S	2.488 x 4.000	7029	.348
#8-5S	2.488 x 5.000	7031	.348
#8-1.625S	2.488 x 1.625	7025	.348

Pre-Set Panning Mating Sills			
Description	"A" Dim. x "B" Dim.	Extrusion Die #99	Slope =
#8-3S	2.488 x 3.000	7027	.348
#3-3S	3.969 x 3.000	7039	.556

Graham Architectural Products reserves the right to change, add, cancel, remove or otherwise modify the details illustrated without prior notice.

1551 Mt. Rose Avenue, York, Pennsylvania 17403-2909 717.849.8100 Toll Free: 800/755-6274

0223 - PPN.09

Web Site: www.grahamwindows.com

Preset Panning Rectangular



Series: Accessories Manufacturing Code: PPN11

Drawing 1/2 Scale – For Custom Size Drawing Contact Graham

Note: Sealant Not Shown On Details. Refer To General Installation Instructions.

Note: Pre-Set Panning Requires The Use Of Equal Leg Sill On Window
Some Pre-Set Panning Require The Use Of Mechanical Corner Keys For
Mitered Assembly. Reference Sheet PPN.CK For Representative Corner Detail.

Canandaigua Pre-Set Panning Head And Jambs			
Description	"A" Dim. x "B" Dim.	Extrusion Die #99	
Canandaigua	1.609 x 2.705	6232	None

Forum Building Pre-Set Panning Head And Jambs			
Description	"A" Dim. x "B" Dim.	Extrusion Die #99	
Forum Building	1.724 x 2.388	6193	None

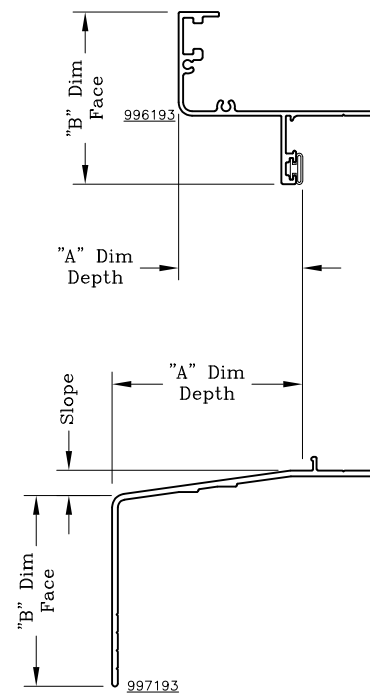
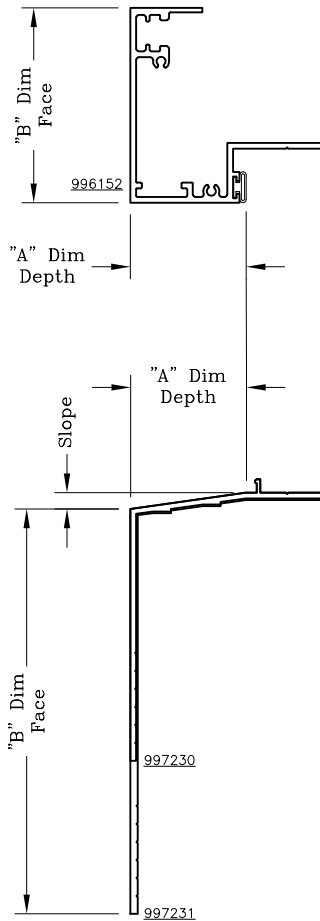

Forum Building Pre-Set Panning Mating Sills			
Description	"A" Dim. x "B" Dim.	Extrusion Die #99	Slope =
Forum Building	2.648 x 2.652	7193	.348

Canadaigua Pre-Set Panning Mating Sills			
Description	"A" Dim. x "B" Dim.	Extrusion Die #99	Slope =
Canadaigua #1	1.609 x 3.500	7230	.224
Canadaigua #1	1.609 x 5.625	7231	.224

Graham Architectural Products reserves the right to change, add, cancel, remove or otherwise modify the details illustrated without prior notice.

1551 Mt. Rose Avenue, York, Pennsylvania 17403-2909 717.849.8100 Toll Free: 800/755-6274

0223 – PPN.11

Web Site: www.grahamwindows.com

Preset Panning Contoured



Series: Accessories Manufacturing Code: PPN12

Drawing 1/2 Scale – For Custom Size Drawing Contact Graham

Note: Sealant Not Shown On Details. Refer To General Installation Instructions.

Note: Pre-Set Panning Requires The Use Of Equal Leg Sill On Window
Some Pre-Set Panning Require The Use Of Mechanical Corner Keys For
Mitered Assembly. Reference Sheet PPN.CK For Representative Corner Detail.

Fulton #1 Pre-Set Panning Head And Jambs			
Description	"A" Dim. x "B" Dim.	Extrusion Die #99	
Fulton #1	2.888 x 2.312	0090	None

Fulton #2 Pre-Set Panning Head And Jambs			
Description	"A" Dim. x "B" Dim.	Extrusion Die #99	
Fulton #2	2.388 x 1.688	6191	None

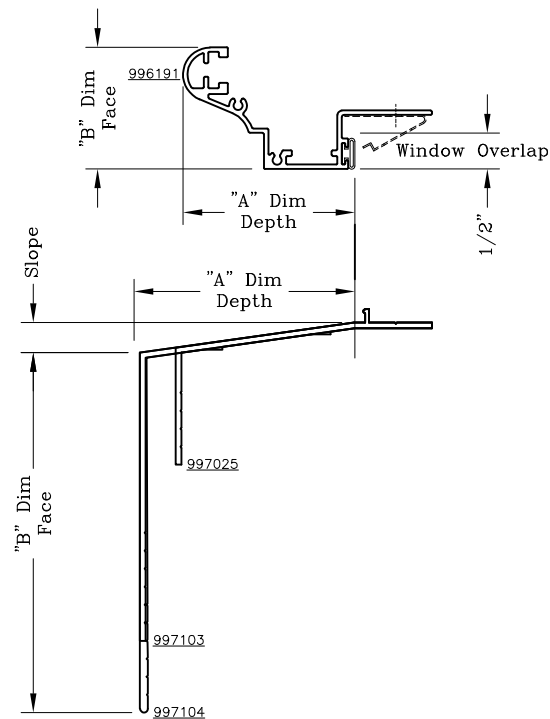
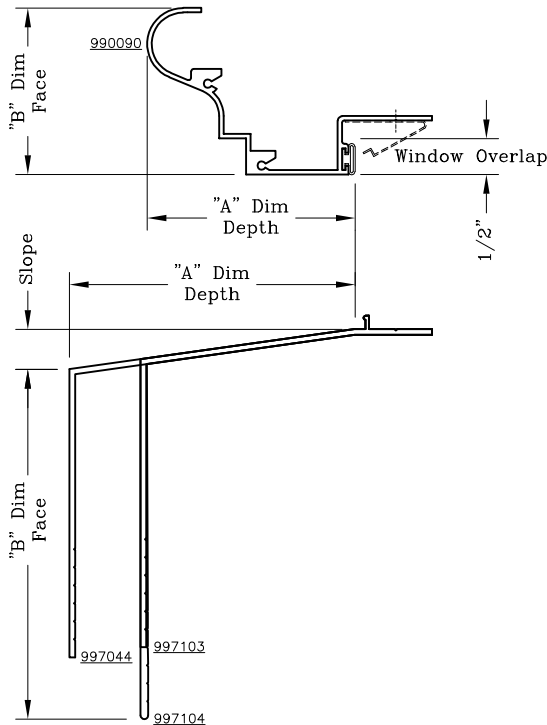

Fulton #1 Pre-Set Panning Mating Sill			
Description	"A" Dim. x "B" Dim.	Extrusion Die #99	Slope =
Del.-4S	2.983 x 4.000	7103	.415
Del.-5S	2.983 x 5.000	7104	.415
#3-4S	3.969 x 4.000	7044	.556

Fulton #2 Pre-Set Panning Mating Sill			
Description	"A" Dim. x "B" Dim.	Extrusion Die #99	Slope =
Del.-4S	2.983 x 4.000	7103	.415
Del.-5S	2.983 x 5.000	7104	.415
Del.-1.625S	2.956 x 1.625	7148	.415
#8-1.6S	2.475 x 1.625	7025	.348

Graham Architectural Products reserves the right to change, add, cancel, remove or otherwise modify the details illustrated without prior notice.

1551 Mt. Rose Avenue, York, Pennsylvania 17403-2909 717.849.8100 Toll Free: 800/755-6274

0223 - PPN.12

Web Site: www.grahamwindows.com

Preset Panning Contoured



Series: Accessories Manufacturing Code: PPN13

Drawing 1/2 Scale – For Custom Size Drawing Contact Graham

Note: Sealant Not Shown On Details. Refer To General Installation Instructions.

Note: Pre-Set Panning Requires The Use Of Equal Leg Sill On Window
Some Pre-Set Panning Require The Use Of Mechanical Corner Keys For
Mitered Assembly. Reference Sheet PPN.CK For Representative Corner Detail.

Essex Pre-Set Panning Head And Jambs			
Description	"A" Dim. x "B" Dim.	Extrusion Die #99	
Essex	3.656 x 3.000	6194	None

U.C. Teachers Pre-Set Panning Head And Jambs			
Description	"A" Dim. x "B" Dim.	Extrusion Die #99	
U.C. Teachers	2.380 x 3.287	6108	None

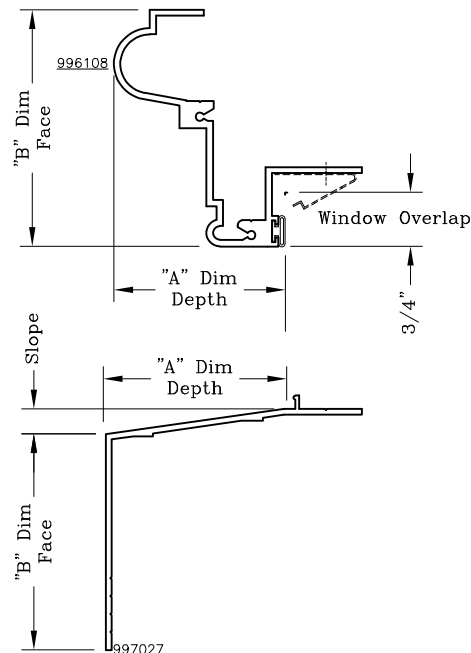
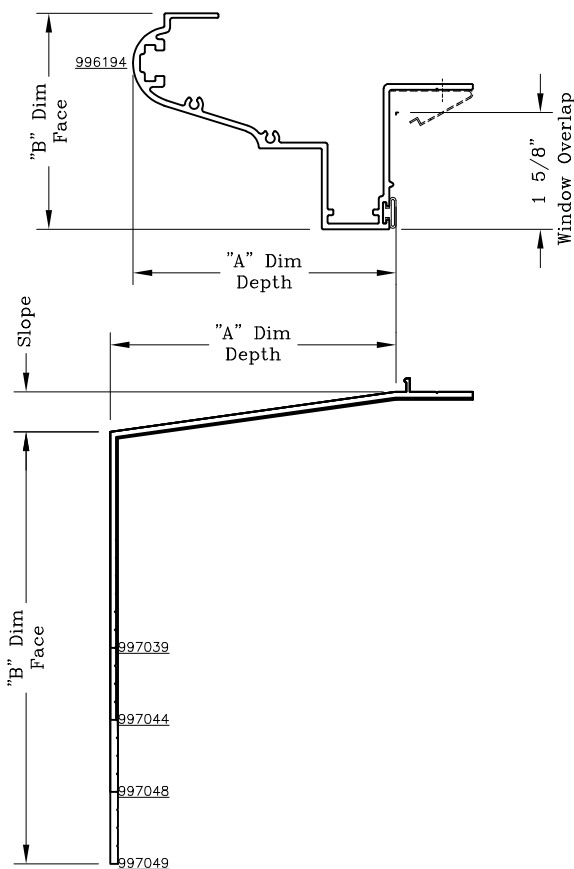

U.C. Teachers Pre-Set Panning Mating Sill			
Description	"A" Dim. x "B" Dim.	Extrusion Die #99	Slope =
#8-3S	2.488 x 3.000	7027	.348

Essex Pre-Set Panning Mating Sills			
Description	"A" Dim. x "B" Dim.	Extrusion Die #99	Slope =
#3-3S	3.956 x 3.000	7039	.556
#3-4S	3.956 x 4.000	7044	.556
#3-5S	3.956 x 5.000	7048	.556
#3-6S	3.956 x 6.000	7049	.556

Graham Architectural Products reserves the right to change, add, cancel, remove or otherwise modify the details illustrated without prior notice.

1551 Mt. Rose Avenue, York, Pennsylvania 17403-2909 717.849.8100 Toll Free: 800/755-6274

0223 – PPN.13

Web Site: www.grahamwindows.com

Preset Panning Contoured



Series: Accessories Manufacturing Code: PPN14

Drawing 1/2 Scale – For Custom Size Drawing Contact Graham

Note: Sealant Not Shown On Details. Refer To General Installation Instructions.

Note: Pre-Set Panning Requires The Use Of Equal Leg Sill On Window
Some Pre-Set Panning Require The Use Of Mechanical Corner Keys For
Mitered Assembly. Reference Sheet PPN.CK For Representative Corner Detail.

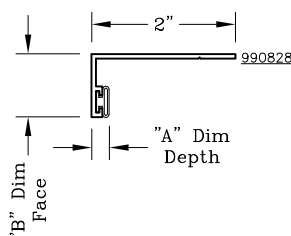
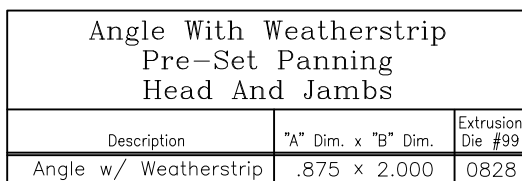
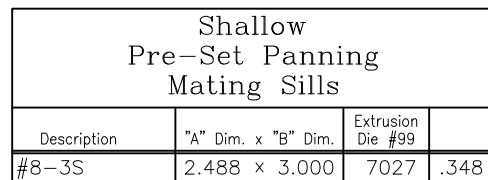
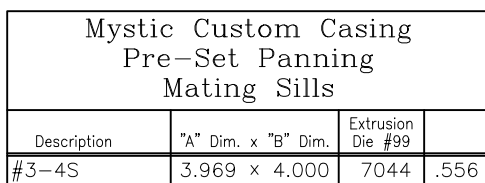
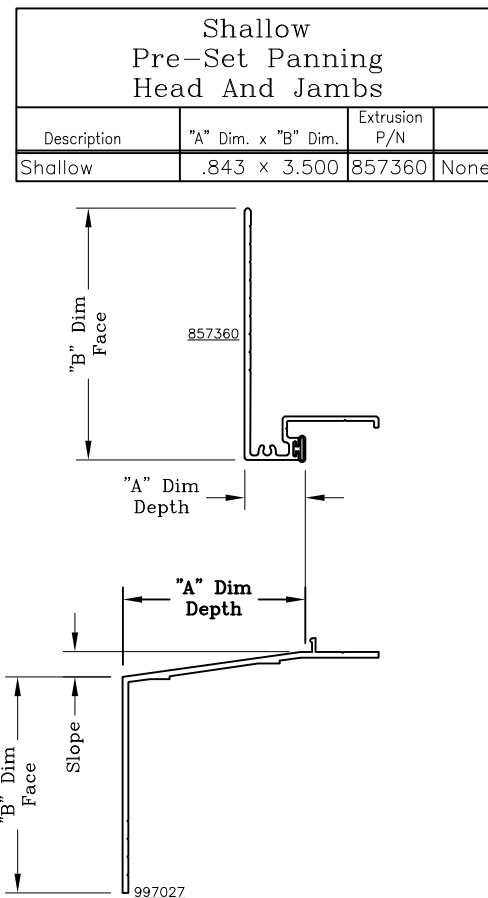
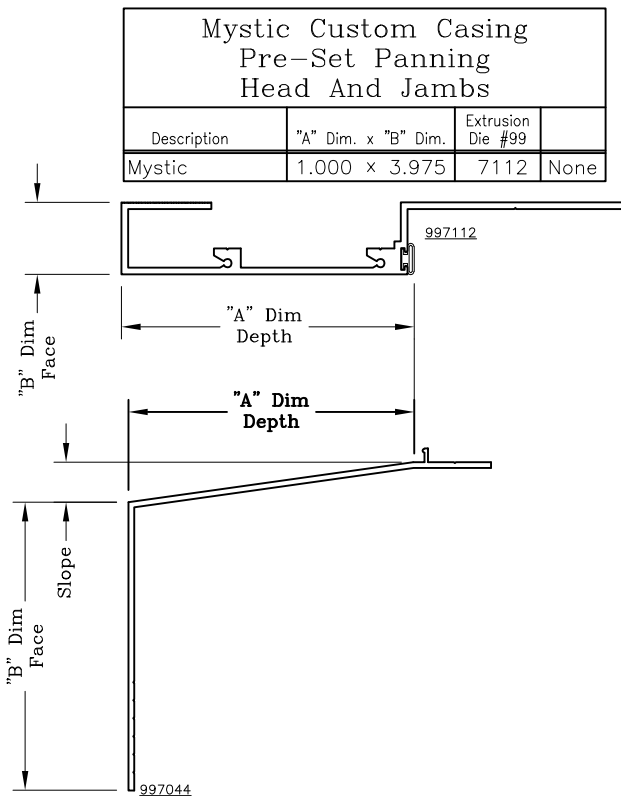

Graham Architectural Products reserves the right to change, add, cancel, remove or otherwise modify the details illustrated without prior notice.

1551 Mt. Rose Avenue, York, Pennsylvania 17403-2909 717.849.8100 Toll Free: 800/755-6274

0223 - PPN.14

Web Site: www.grahamwindows.com

Preset Panning Contoured



Series: Accessories Manufacturing Code: PPN15

Drawing 1/2 Scale – For Custom Size Drawing Contact Graham

Note: Sealant Not Shown On Details. Refer To General Installation Instructions.

Note: Pre-Set Panning Requires The Use Of Equal Leg Sill On Window
Some Pre-Set Panning Require The Use Of Mechanical Corner Keys For
Mitered Assembly. Reference Sheet PPN.CK For Representative Corner Detail.

North HS Pre-Set Panning Head And Jambs			
Description	"A" Dim. x "B" Dim.	Extrusion Die #99	
North HS	6.512 x 3.187	1174	None

Sprout Pre-Set Panning Head And Jambs			
Description	"A" Dim. x "B" Dim.	Extrusion Die #99	
Sprout	2.562 x 2.000	1170	None

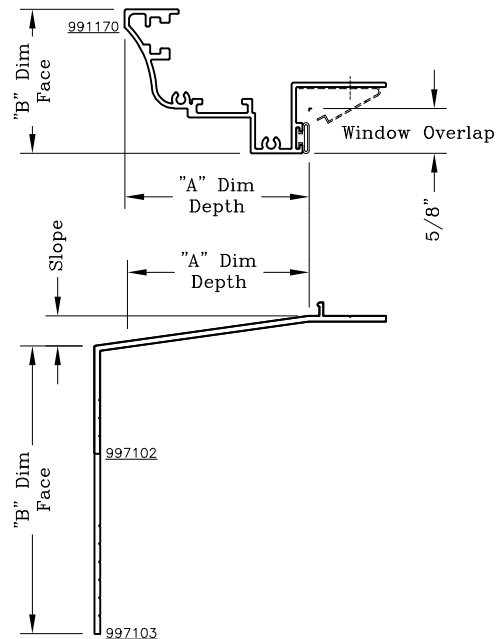
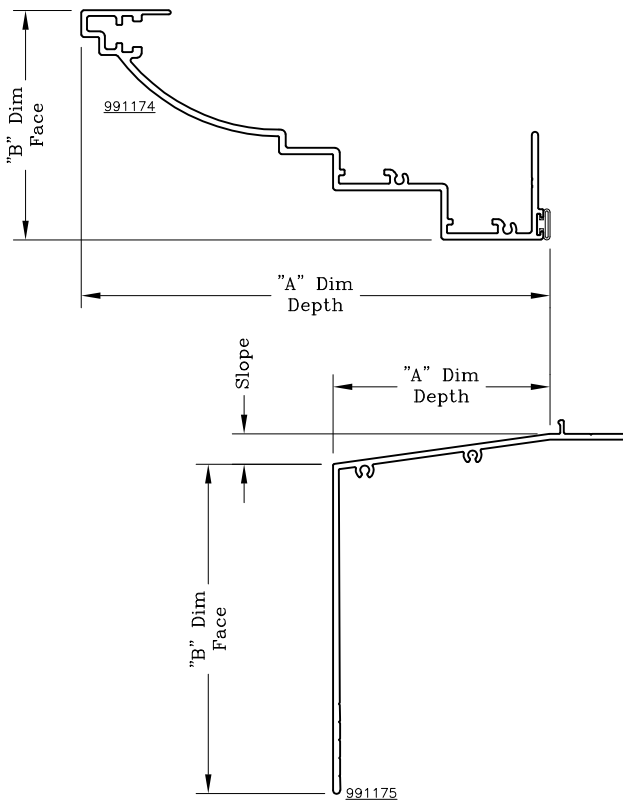

North HS Pre-Set Panning Mating Sills			
Description	"A" Dim. x "B" Dim.	Extrusion Die #99	Slope =
North HS	3.016 x 4.578	1175	.422

Sprout Pre-Set Panning Mating Sill			
Description	"A" Dim. x "B" Dim.	Extrusion Die #99	Slope =
Del.-1.5S	2.983 x 1.500	7102	.417
Del.-4S	2.983 x 4.000	7103	.417

Preset Panning Contoured



Series: Accessories Manufacturing Code: PPN16

Drawing 1/2 Scale – For Custom Size Drawing Contact Graham

Note: Sealant Not Shown On Details. Refer To General Installation Instructions.

Note: Pre-Set Panning Requires The Use Of Equal Leg Sill On Window
Some Pre-Set Panning Require The Use Of Mechanical Corner Keys For
Mitered Assembly. Reference Sheet PPN.CK For Representative Corner Detail.

Ridges Pre-Set Panning Head And Jambs			
Description	"A" Dim. x "B" Dim.	Extrusion Die #99	
Ridges	3.936 x 2.125	6024	None

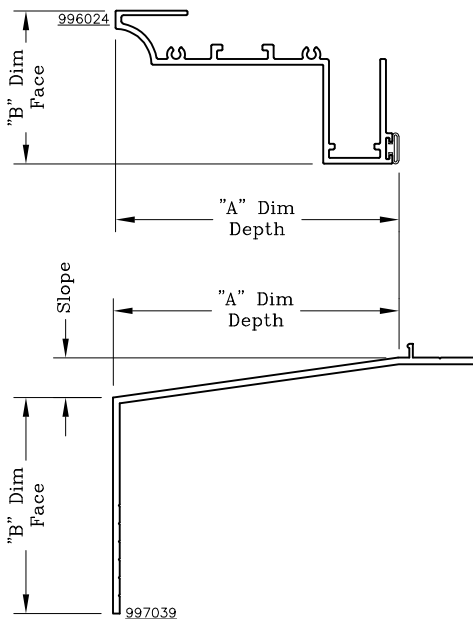

Municipal Light Pre-Set Panning Head And Jambs			
Description	"A" Dim. x "B" Dim.	Extrusion Die #99	
Municipal Light	.905 x 2.000	6025	None

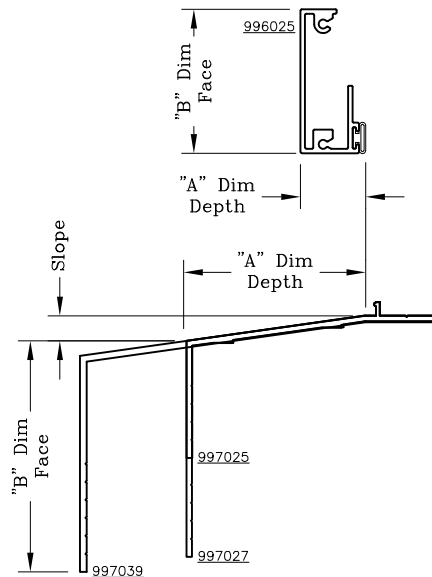

Ridges Pre-Set Panning Mating Sills			
Description	"A" Dim. x "B" Dim.	Extrusion Die #99	Slope =
#3-3S	3.969 x 3.000	7039	.556

Municipal Light Pre-Set Panning Mating Sill			
Description	"A" Dim. x "B" Dim.	Extrusion Die #99	Slope =
#8-1.625S	2.488 x 1.625	7025	.348
#8-3S	2.488 x 3.000	7027	.348
#3-3S	3.969 x 3.000	7039	.556

Preset Panning Contoured



Series: Accessories Manufacturing Code: PPN17

Drawing 1/2 Scale – For Custom Size Drawing Contact Graham

Note: Sealant Not Shown On Details. Refer To General Installation Instructions.

Note: Pre-Set Panning Requires The Use Of Equal Leg Sill On Window
Some Pre-Set Panning Require The Use Of Mechanical Corner Keys For
Mitered Assembly. Reference Sheet PPN.CK For Representative Corner Detail.

Mariemont/Snead Pre-Set Panning Head And Jambs			
Description	"A" Dim. x "B" Dim.	Extrusion Die #99	
Mariemont	2.180 x 2.250	6127	None

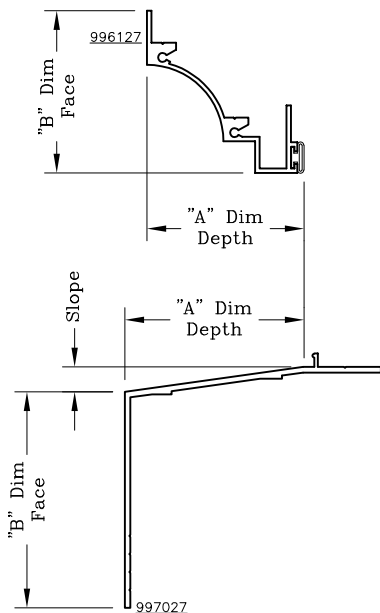

Clap Hall Pre-Set Panning Head And Jambs			
Description	"A" Dim. x "B" Dim.	Extrusion Die #99	
Baldwin Hall	2.308 x 1.250	6126	None

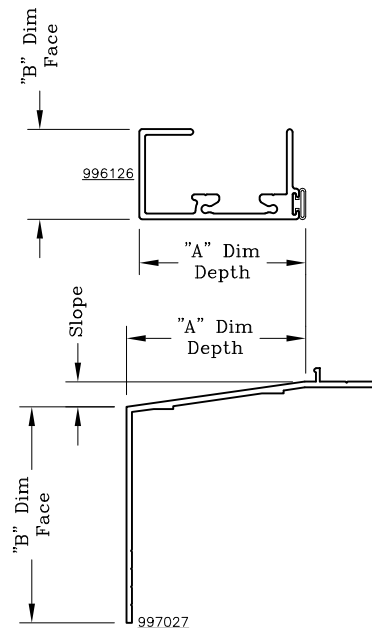

Mariemont/Snead Pre-Set Panning Mating Sills			
Description	"A" Dim. x "B" Dim.	Extrusion Die #99	Slope =
#8-3S	2.488 x 3.000	7027	.348

Clap Hall Pre-Set Panning Mating Sill			
Description	"A" Dim. x "B" Dim.	Extrusion Die #99	Slope =
#8-3S	2.488 x 3.000	7027	.348

Graham Architectural Products reserves the right to change, add, cancel, remove or otherwise modify the details illustrated without prior notice.

1551 Mt. Rose Avenue, York, Pennsylvania 17403-2909 717.849.8100 Toll Free: 800/755-6274

0223 – PPN.17

Web Site: www.grahamwindows.com

Preset Panning Contoured



Series: Accessories Manufacturing Code: PPN18

Drawing 1/2 Scale – For Custom Size Drawing Contact Graham

Note: Sealant Not Shown On Details. Refer To General Installation Instructions.

Note: Pre-Set Panning Requires The Use Of Equal Leg Sill On Window
Some Pre-Set Panning Require The Use Of Mechanical Corner Keys For
Mitered Assembly. Reference Sheet PPN.CK For Representative Corner Detail.

Dickinson/CWTC Pre-Set Panning Head And Jambs			
Description	"A" Dim. x "B" Dim.	Extrusion Die #99	
Dickinson	2.280 x 4.500	6177	None

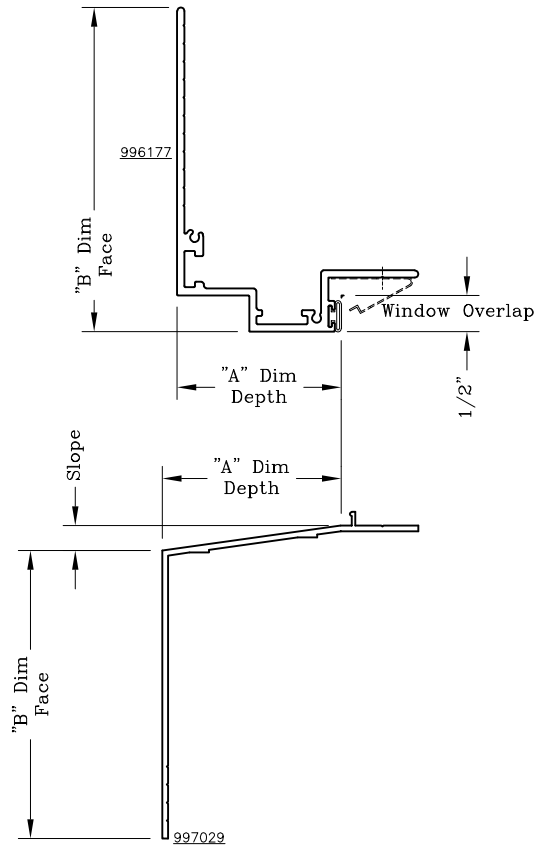

Dickinson Pre-Set Panning Mating Sills			
Description	"A" Dim. x "B" Dim.	Extrusion Die #99	Slope =
#8-4S	2.488 x 4.000	7029	.348

Metro Pre-Set Panning Head And Jambs			
Description	"A" Dim. x "B" Dim.	Extrusion Die #99	
Metro	1.513 x 2.437	6150	None

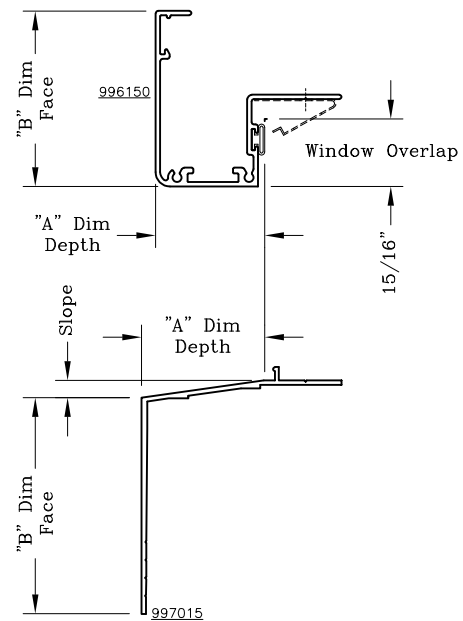

Metro Pre-Set Panning Mating Sill			
Description	"A" Dim. x "B" Dim.	Extrusion Die #99	Slope =
#10-3S	1.711 x 3.000	7015	.239

Preset Panning Contoured



Series: Accessories Manufacturing Code: PPN19

Drawing 1/2 Scale – For Custom Size Drawing Contact Graham

Note: Sealant Not Shown On Details. Refer To General Installation Instructions.

Note: Pre-Set Panning Requires The Use Of Equal Leg Sill On Window
Some Pre-Set Panning Require The Use Of Mechanical Corner Keys For
Mitered Assembly. Reference Sheet PPN.CK For Representative Corner Detail.

Grand River Contour Pre-Set Panning Head And Jambs			
Description	"A" Dim. x "B" Dim.	Extrusion Die #99	
Grand River	1.597 x 2.125	6154	None

Grand River Stepped Pre-Set Panning Head, Jambs And Sill			
Description	"A" Dim. x "B" Dim.	Extrusion Die #99	
Grand River Step	1.263 x 2.000	6155	None

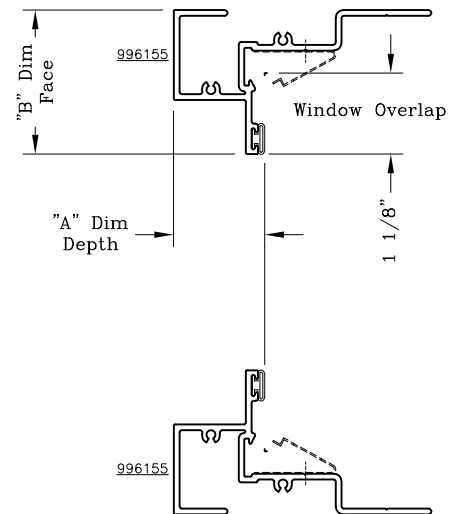
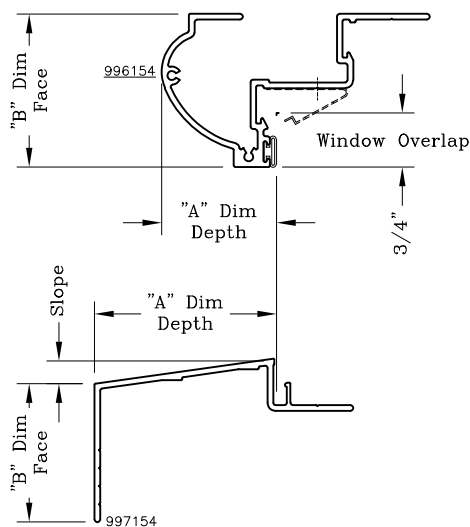

Contact Graham For
Additional Sill Panning Options

Grand River Pre-Set Panning Mating Sills			
Description	"A" Dim. x "B" Dim.	Extrusion Die #99	Slope =
Grand River	2.286 x 3.000	7154	.320

Preset Panning Contoured



Series: Accessories Manufacturing Code: PPN20

Drawing 1/2 Scale – For Custom Size Drawing Contact Graham

Note: Sealant Not Shown On Details. Refer To General Installation Instructions.

Note: Pre-Set Panning Requires The Use Of Equal Leg Sill On Window
Some Pre-Set Panning Require The Use Of Mechanical Corner Keys For
Mitered Assembly. Reference Sheet PPN.CK For Representative Corner Detail.

1 Penn Pre-Set Panning Head And Jambs			
Description	"A" Dim. x "B" Dim.	Extrusion Die #99	
1 Penn Head	2.104 x 2.203	6156	None
1 Penn Jamb	1.964 x 1.359	6157	None

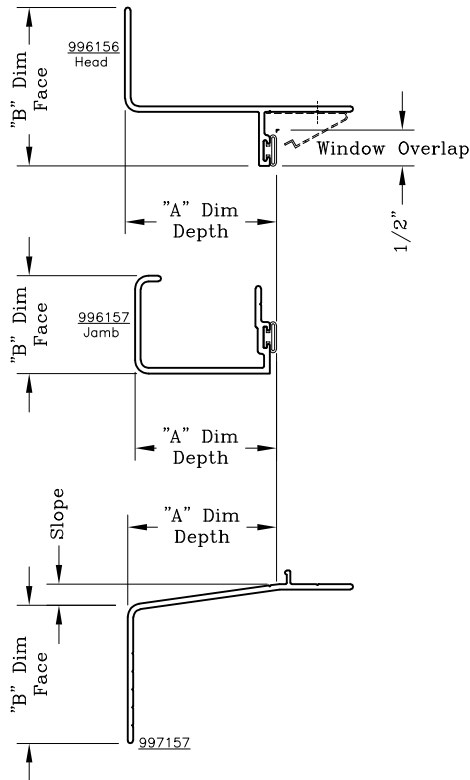

13th and U Pre-Set Panning Head, Jambs And Sill			
Description	"A" Dim. x "B" Dim.	Extrusion Die #99	
13th and U	1.000 x 1.000	6098	None

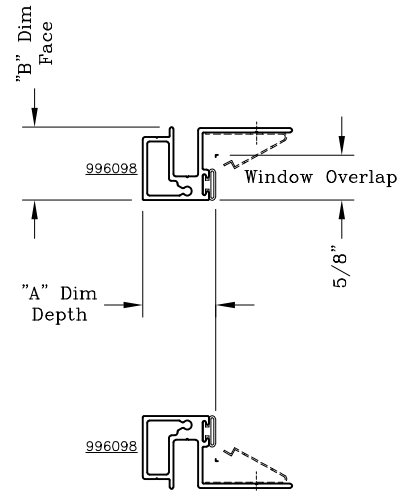

Contact Graham For Additional
Sill Panning Options

1 Penn Pre-Set Panning Sill			
Description	"A" Dim. x "B" Dim.	Extrusion Die #99	Slope =
1 Penn Sill	2.062 x 1.917	7157	.296

Individual Head, Jamb And Sill
Field Set Into Opening

Preset Panning Contoured



Series: Accessories Manufacturing Code: PPN21

Drawing 1/2 Scale – For Custom Size Drawing Contact Graham

Note: Sealant Not Shown On Details. Refer To General Installation Instructions.

Note: Pre-Set Panning Requires The Use Of Equal Leg Sill On Window
Some Pre-Set Panning Require The Use Of Mechanical Corner Keys For
Mitered Assembly. Reference Sheet PPN.CK For Representative Corner Detail.

Norman Towers Pre-Set Panning Head And Jamb			
Description	"A" Dim. x "B" Dim.	Extrusion Die #99	
Norman Towers	2.016 x 2.125	6158	None

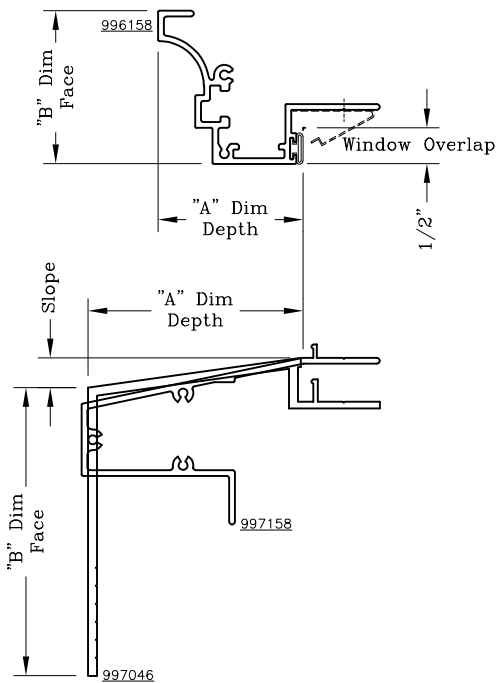

Cristo Rey Pre-Set Panning Head And Jamb			
Description	"A" Dim. x "B" Dim.	Extrusion Die #99	
Cristo Rey	2.562 x 2.625	6162	None

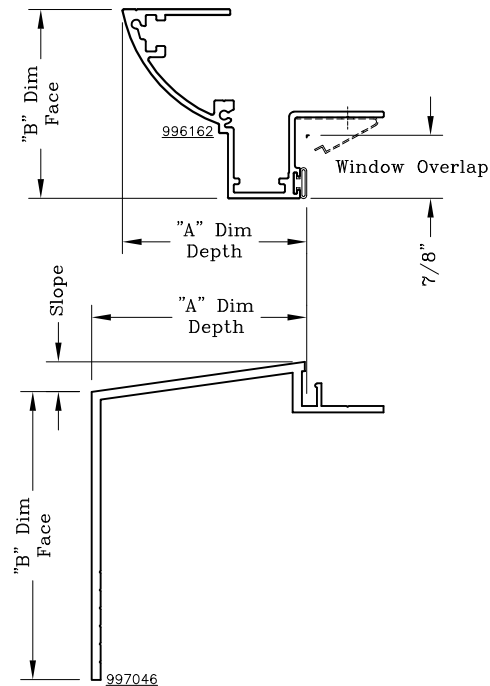

Norman Towers Pre-Set Panning Mating Sills			
Description	"A" Dim. x "B" Dim.	Extrusion Die #99	Slope =
Norman	3.061 x .973	7027	.635
Del-BOE	2.290 x 4.000	7046	.415

Cristo Rey Pre-Set Panning Mating Sill			
Description	"A" Dim. x "B" Dim.	Extrusion Die #99	Slope =
Del-BOE	2.290 x 4.000	7046	.415

Preset Panning Contoured



Series: Accessories Manufacturing Code: PPN22

Drawing 1/2 Scale – For Custom Size Drawing Contact Graham

Note: Sealant Not Shown On Details. Refer To General Installation Instructions.

Note: Pre-Set Panning Requires The Use Of Equal Leg Sill On Window
Some Pre-Set Panning Require The Use Of Mechanical Corner Keys For
Mitered Assembly. Reference Sheet PPN.CK For Representative Corner Detail.

Nortic – Rectangular Pre-Set Panning Head And Jambs			
Description	"A" Dim. x "B" Dim.	Extrusion Die #99	
Nortic Rectangle	3.933 x 2.750	6160	None

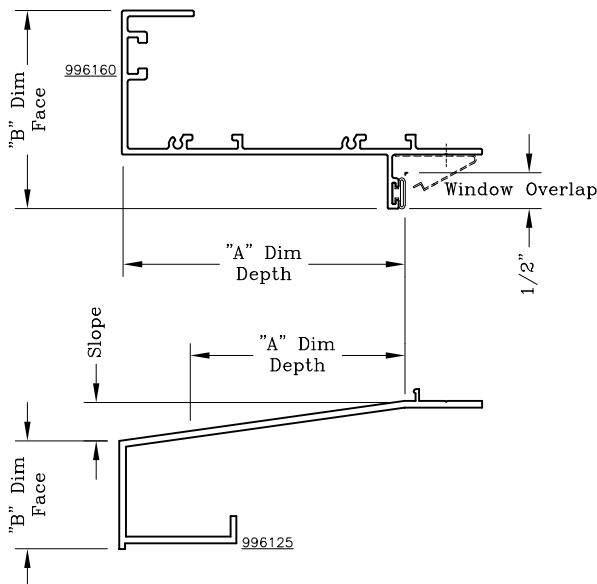

Nortic – Contoured Pre-Set Panning Head And Jambs			
Description	"A" Dim. x "B" Dim.	Extrusion Die #99	
Nortic Contoured	3.933 x 2.750	6161	None

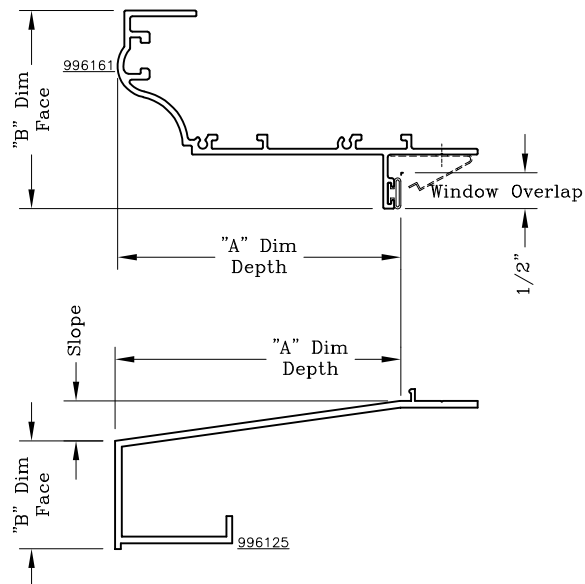

Nortic – Rectangular Pre-Set Panning Mating Sills			
Description	"A" Dim. x "B" Dim.	Extrusion Die #99	Slope =
Clapp Hall	3.969 x 1.500	6125	.556

Nortic – Contoured Pre-Set Panning Mating Sill			
Description	"A" Dim. x "B" Dim.	Extrusion Die #99	Slope =
Clap Hall	3.969 x 1.500	6125	.556

Preset Panning Contoured



Series: Accessories Manufacturing Code: PPN23

Drawing 1/2 Scale – For Custom Size Drawing Contact Graham

Note: Sealant Not Shown On Details. Refer To General Installation Instructions.

Note: Pre-Set Panning Requires The Use Of Equal Leg Sill On Window
Some Pre-Set Panning Require The Use Of Mechanical Corner Keys For
Mitered Assembly. Reference Sheet PPN.CK For Representative Corner Detail.

Chicago Tribune Pre-Set Panning Head And Jamb			
Description	"A" Dim. x "B" Dim.	Extrusion Die #99	
Tribune Head	3.218 x 4.000	6165	None
Tribune Jamb	2.718 x 1.922	6164	None

Chicago Tribune Pre-Set Panning Head, Jamb			
Description	"A" Dim. x "B" Dim.	Extrusion Die #99	
Chicago Tribune	2.718 x 4.500	6163	None

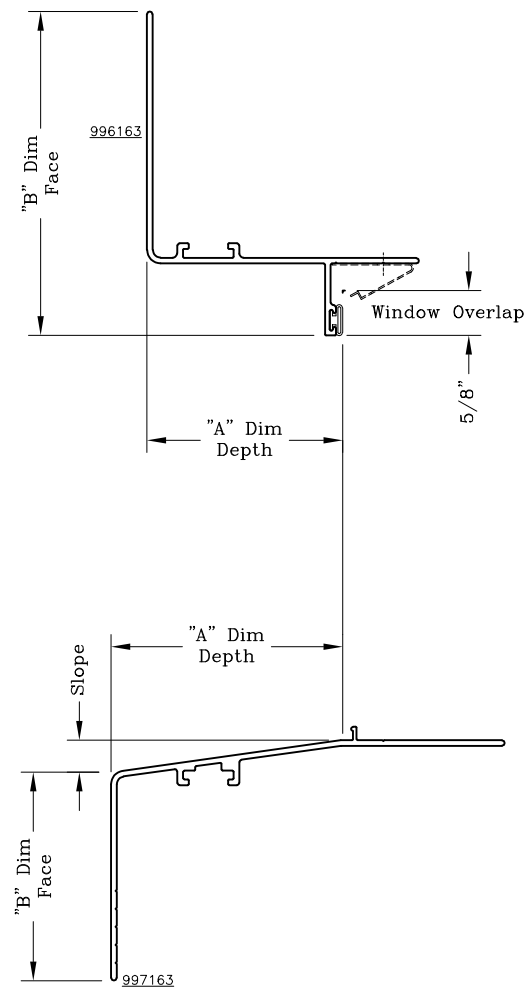
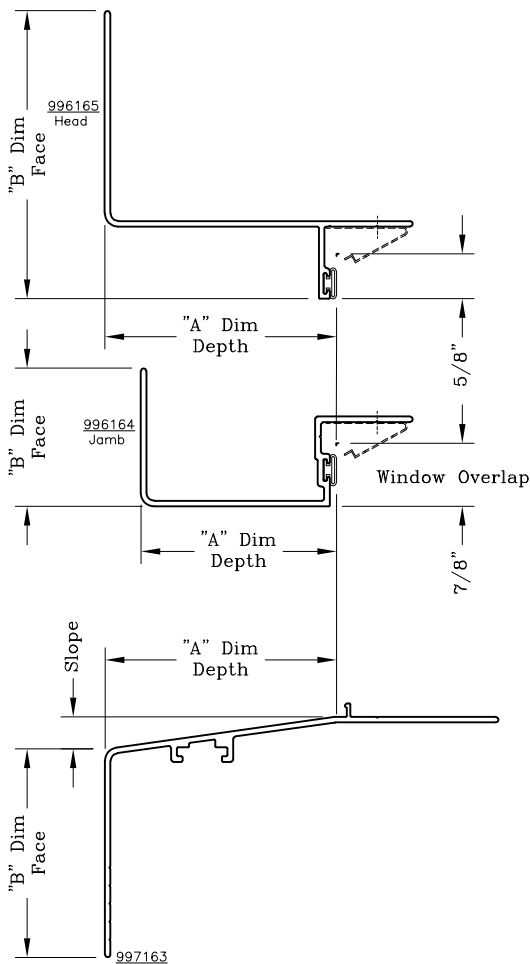

Chicago Tribune Pre-Set Panning Sill			
Description	"A" Dim. x "B" Dim.	Extrusion Die #99	Slope =
Tribune Sill	3.216 x 2.875	7163	.448

Chicago Tribune Pre-Set Panning Sill			
Description	"A" Dim. x "B" Dim.	Extrusion Die #99	Slope =
Tribune Sill	3.216 x 2.875	7163	.448

Individual Head, Jamb And Sill
Field Set Into Opening

Graham Architectural Products reserves the right to change, add, cancel, remove or otherwise modify the details illustrated without prior notice.

1551 Mt. Rose Avenue, York, Pennsylvania 17403-2909 717.849.8100 Toll Free: 800/755-6274

0223 – PPN.23

Web Site: www.grahamwindows.com

Preset Panning Contoured



Series: Accessories Manufacturing Code: PPN25

Drawing 1/2 Scale – For Custom Size Drawing Contact Graham

Note: Sealant Not Shown On Details. Refer To General Installation Instructions.

Note: Pre-Set Panning Requires The Use Of Equal Leg Sill On Window
Some Pre-Set Panning Require The Use Of Mechanical Corner Keys For
Mitered Assembly. Reference Sheet PPN.CK For Representative Corner Detail.

WSU Chatworth Pre-Set Panning Head And Jambs			
Description	"A" Dim. x "B" Dim.	Extrusion Die #99	
WSU Chatworth	1.151 x 2.290	6170	None

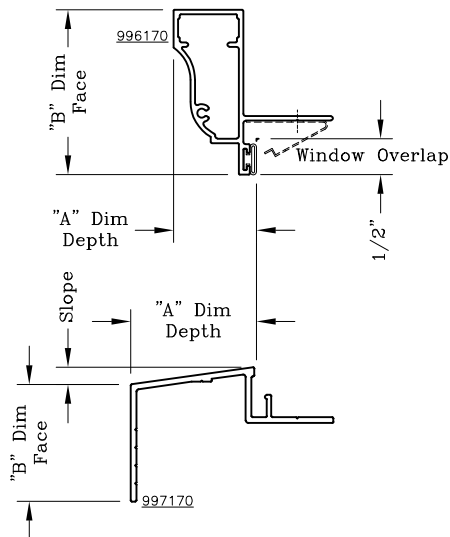

Provent/Snead Pre-Set Panning Head And Jambs			
Description	"A" Dim. x "B" Dim.	Extrusion Die #99	
Provent/Snead	2.180 x 1.806	6171	None

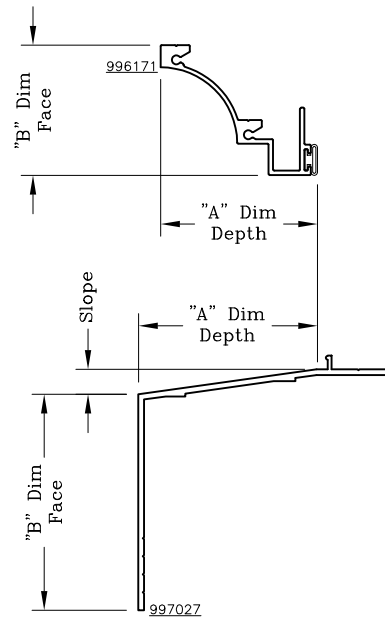

WSU Chatworth Pre-Set Panning Mating Sills			
Description	"A" Dim. x "B" Dim.	Extrusion Die #99	Slope =
WSU Chatworth	1.625 x 1.500	7170	.239

Provent/Snead Pre-Set Panning Mating Sill			
Description	"A" Dim. x "B" Dim.	Extrusion Die #99	Slope =
#8-3S	2.488 x 3.000	7027	.348

Preset Panning Contoured



Series: Accessories Manufacturing Code: PPN26

Drawing 1/2 Scale – For Custom Size Drawing Contact Graham

Note: Sealant Not Shown On Details. Refer To General Installation Instructions.

Note: Pre-Set Panning Requires The Use Of Equal Leg Sill On Window
Some Pre-Set Panning Require The Use Of Mechanical Corner Keys For
Mitered Assembly. Reference Sheet PPN.CK For Representative Corner Detail.

548 West 28th Pre-Set Panning Head And Jambs			
Description	"A" Dim. x "B" Dim.	Extrusion Die #99	
548 West 28th	2.125 x 2.625	6172	None

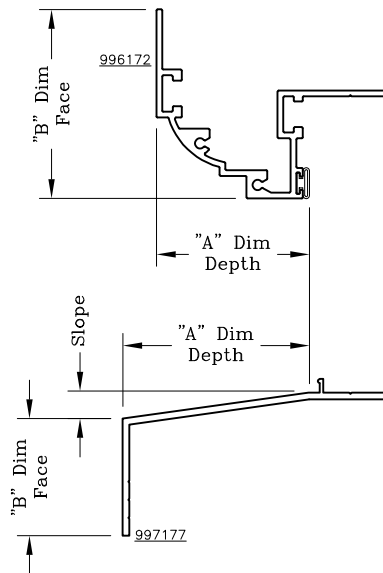

548 West 28th Pre-Set Panning Mating Sills			
Description	"A" Dim. x "B" Dim.	Extrusion Die #99	Slope =
548 West 28th	2.593 x 1.625	7177	.363

William Penn #4 Pre-Set Panning Head And Jambs			
Description	"A" Dim. x "B" Dim.	Extrusion Die #99	
William Penn #4	2.944 x 3.000	6181	None

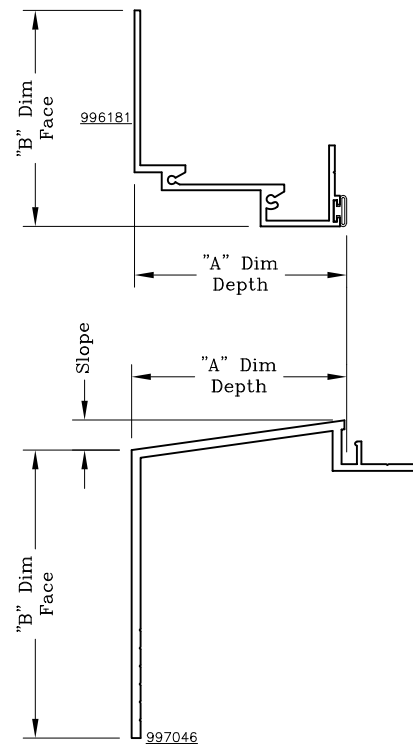

William Penn #4 Pre-Set Panning Mating Sill			
Description	"A" Dim. x "B" Dim.	Extrusion Die #99	Slope =
Del-BOE	2.984 x 4.000	7046	.415

Preset Panning Contoured



Series: Accessories Manufacturing Code: PPN27

Drawing 1/2 Scale – For Custom Size Drawing Contact Graham

Note: Sealant Not Shown On Details. Refer To General Installation Instructions.

Note: Pre-Set Panning Requires The Use Of Equal Leg Sill On Window
Some Pre-Set Panning Require The Use Of Mechanical Corner Keys For
Mitered Assembly. Reference Sheet PPN.CK For Representative Corner Detail.

Cook 1 Pre-Set Panning Head And Jambs			
Description	"A" Dim. x "B" Dim.	Extrusion Die #99	
Cook 1	4.750 x 2.687	6173	None

Cook 2 Pre-Set Panning Head And Jambs			
Description	"A" Dim. x "B" Dim.	Extrusion Die #99	
Cook 2	1.948 x 2.875	6174	None

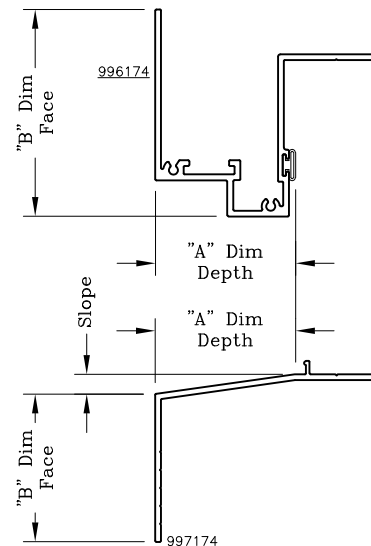
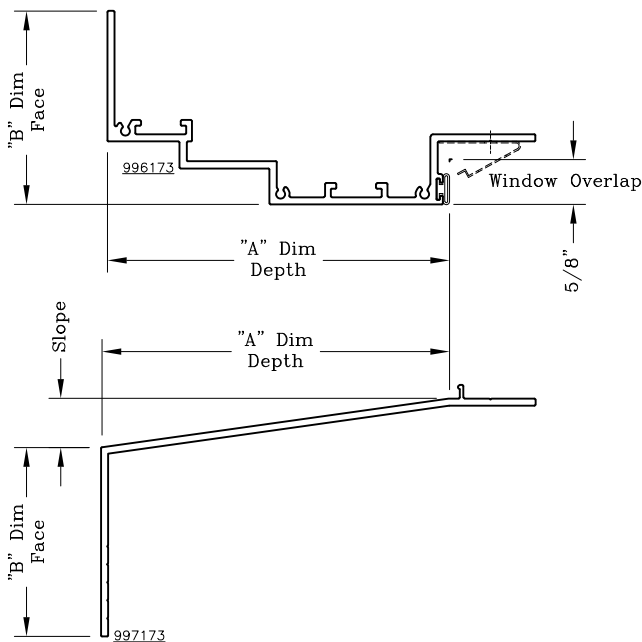

Cook 1 Pre-Set Panning Mating Sills			
Description	"A" Dim. x "B" Dim.	Extrusion Die #99	Slope =
Cook 1	4.840 x 2.625	7173	.679

Cook 2 Pre-Set Panning Mating Sill			
Description	"A" Dim. x "B" Dim.	Extrusion Die #99	Slope =
Cook 2	1.950 x 2.054	7174	.272

Preset Panning Contoured



Series: Accessories Manufacturing Code: PPN28

Drawing 1/2 Scale – For Custom Size Drawing Contact Graham

Note: Sealant Not Shown On Details. Refer To General Installation Instructions.

Note: Pre-Set Panning Requires The Use Of Equal Leg Sill On Window
Some Pre-Set Panning Require The Use Of Mechanical Corner Keys For
Mitered Assembly. Reference Sheet PPN.CK For Representative Corner Detail.

Cook 3 Pre-Set Panning Head And Jambs			
Description	"A" Dim. x "B" Dim.	Extrusion Die #99	
Cook 3	1.948 x 2.875	6175	None

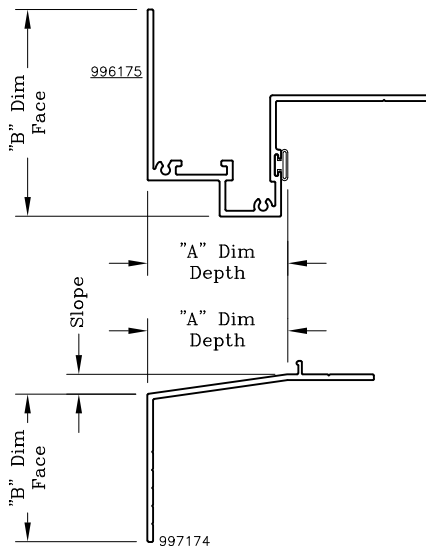

Cook 4 Pre-Set Panning Head And Jambs			
Description	"A" Dim. x "B" Dim.	Extrusion Die #99	
Cook 4	4.531 x 3.050	6176	None

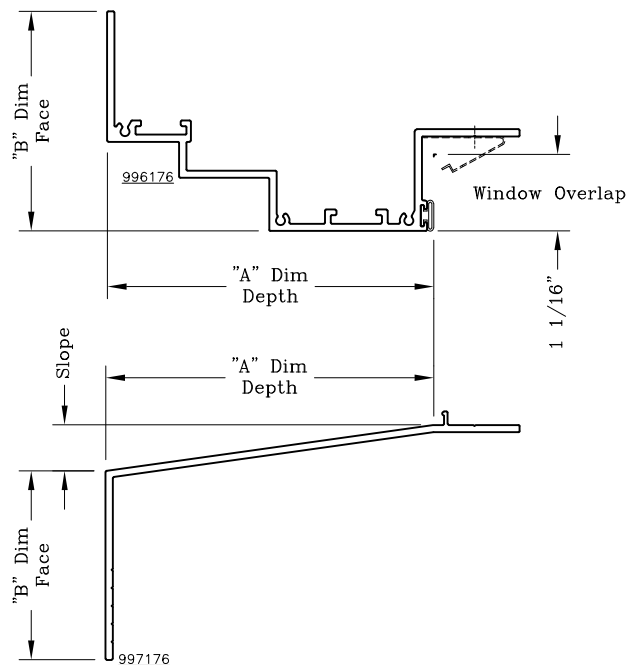

Cook 3 Pre-Set Panning Mating Sill			
Description	"A" Dim. x "B" Dim.	Extrusion Die #99	Slope =
Cook 2	1.950 x 2.054	7174	.272

Cook 4 Pre-Set Panning Mating Sills			
Description	"A" Dim. x "B" Dim.	Extrusion Die #99	Slope =
Cook 4	4.553 x 2.625	7176	.638

Preset Panning Contoured



Series: Accessories Manufacturing Code: PPN29

Drawing 1/2 Scale – For Custom Size Drawing Contact Graham

Note: Sealant Not Shown On Details. Refer To General Installation Instructions.

Note: Pre-Set Panning Requires The Use Of Equal Leg Sill On Window
Some Pre-Set Panning Require The Use Of Mechanical Corner Keys For
Mitered Assembly. Reference Sheet PPN.CK For Representative Corner Detail.

21c Museum Pre-Set Panning Head And Jambs			
Description	"A" Dim. x "B" Dim.	Extrusion Die #99	
21c Museum	2.481 x 2.000	6188	None

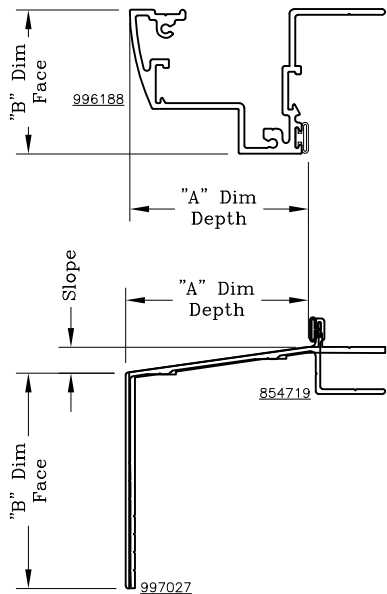

21c Museum Pre-Set Panning Mating Sills			
Description	"A" Dim. x "B" Dim.	Extrusion Die	Slope =
#8-3S	2.488 x 3.000	997027	.348
St Paul	2.538 x 3.000	854719	.364

Shelbyville Pre-Set Panning Head And Jambs			
Description	"A" Dim. x "B" Dim.	Extrusion Die #99	
Shelbyville	3.945 x 4.250	6190	None

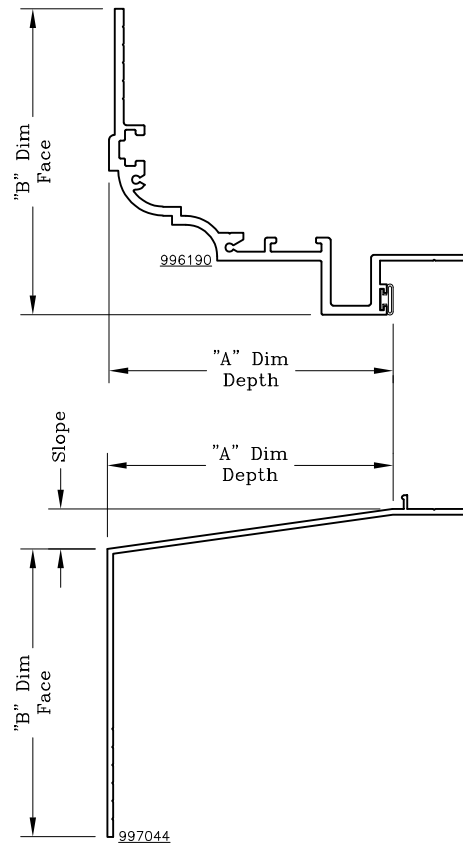

Shelbyville Pre-Set Panning Mating Sill			
Description	"A" Dim. x "B" Dim.	Extrusion Die #99	Slope =
#3-4S	3.969 x 4.000	7044	.556

Preset Panning Contoured



Series: Accessories Manufacturing Code: PPN30

Drawing 1/2 Scale – For Custom Size Drawing Contact Graham

Note: Sealant Not Shown On Details. Refer To General Installation Instructions.

Note: Pre-Set Panning Requires The Use Of Equal Leg Sill On Window
Some Pre-Set Panning Require The Use Of Mechanical Corner Keys For
Mitered Assembly. Reference Sheet PPN.CK For Representative Corner Detail.

Maderia Pre-Set Panning Head, Jambs And Mullion			
Description	"A" Dim. x "B" Dim.	Extrusion Die #99	
Maderia H/S	2.000 x 3.750	6231	None
Maderia Mull	1.000 x 5.000	6216	None

GE Electric Works Pre-Set Panning Head And Jambs			
Description	"A" Dim. x "B" Dim.	Extrusion Die #99	
GE Electric Works	2.188 x 2.750	6178	None

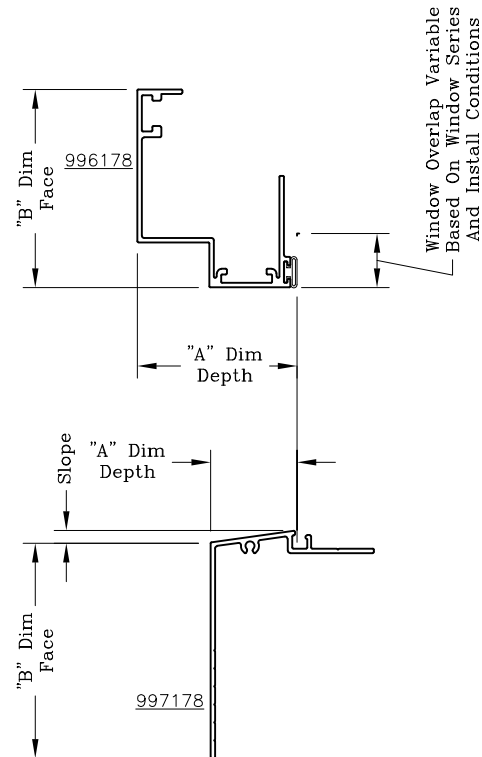
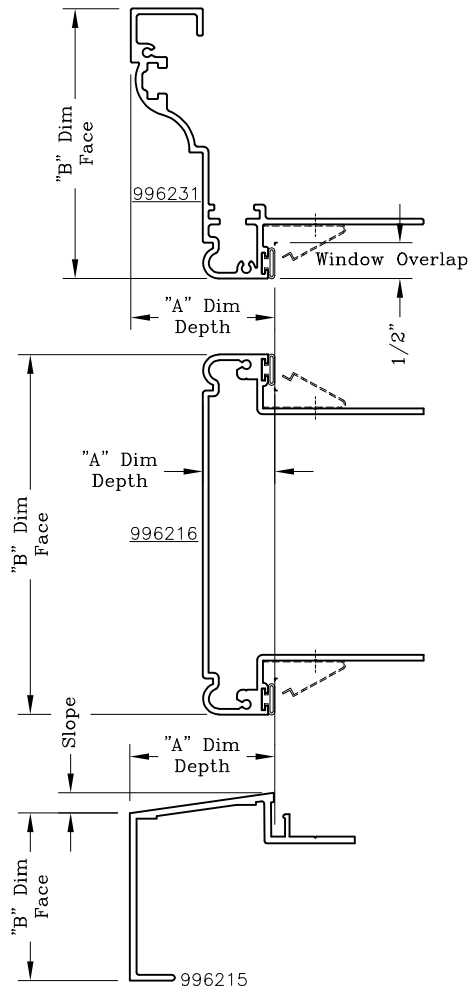

GE Electric Works Pre-Set Panning Mating Sill			
Description	"A" Dim. x "B" Dim.	Extrusion Die #99	Slope =
GE Electric Works	1.200 x 3.000	7178	.164

Maderia Pre-Set Panning Mating Sill			
Description	"A" Dim. x "B" Dim.	Extrusion Die #99	Slope =
Maderia Sill	2.016 x 2.328	6215	.281

Graham Architectural Products reserves the right to change, add, cancel, remove or otherwise modify the details illustrated without prior notice.

1551 Mt. Rose Avenue, York, Pennsylvania 17403-2909 717.849.8100 Toll Free: 800/755-6274

0223 – PPN.30

Web Site: www.grahamwindows.com

Preset Panning Contoured



Series: Accessories Manufacturing Code: PPN31

Drawing 1/2 Scale – For Custom Size Drawing Contact Graham

Note: Sealant Not Shown On Details. Refer To General Installation Instructions.

Note: Pre-Set Panning Requires The Use Of Equal Leg Sill On Window
Some Pre-Set Panning Require The Use Of Mechanical Corner Keys For
Mitered Assembly. Reference Sheet PPN.CK For Representative Corner Detail.

Yorktown Hotel Pre-Set Panning Head And Jambs			
Description	"A" Dim. x "B" Dim.	Extrusion Die #99	
Yorktown	3.965 x 2.812	6218	None

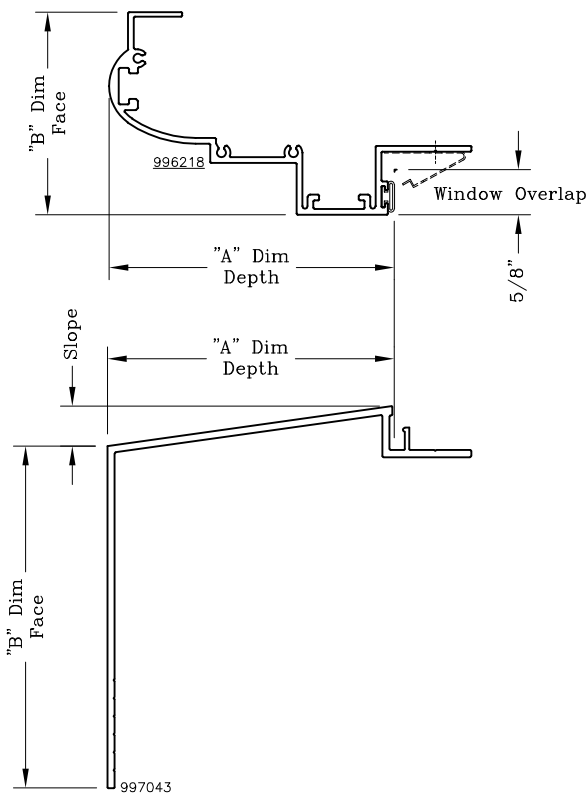

Yorktown Hotel Pre-Set Panning Mating Sills			
Description	"A" Dim. x "B" Dim.	Extrusion Die #99	Slope =
#3-4.75 BOE	3.985 x 4.750	7043	.556

Belden Stratford Pre-Set Panning Head And Jambs			
Description	"A" Dim. x "B" Dim.	Extrusion Die #99	
Belden Stratford	3.745 x 2.000	6219	None

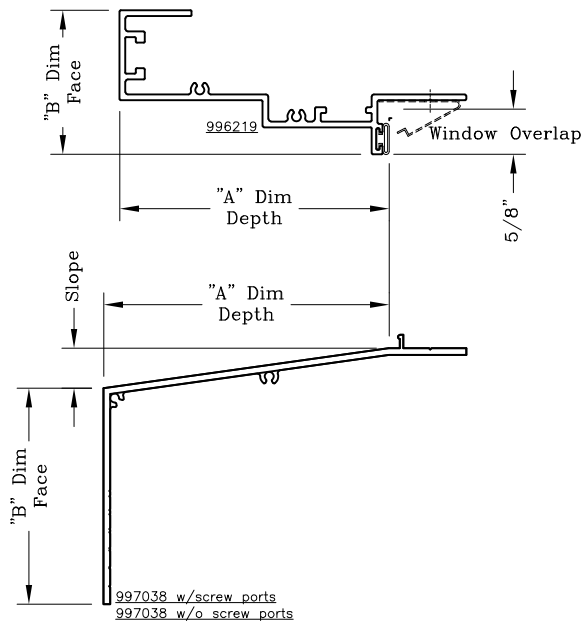

Belden Stratford Pre-Set Panning Mating Sill			
Description	"A" Dim. x "B" Dim.	Extrusion Die #99	Slope =
#3-3S	3.969 x 3.000	7039	.556
#3-3S w/ ports	3.969 x 3.000	7038	.556

Preset Panning Contoured



Series: Accessories Manufacturing Code: PPN32

Drawing 1/2 Scale – For Custom Size Drawing Contact Graham

Note: Sealant Not Shown On Details. Refer To General Installation Instructions.

Note: Pre-Set Panning Requires The Use Of Equal Leg Sill On Window
Some Pre-Set Panning Require The Use Of Mechanical Corner Keys For
Mitered Assembly. Reference Sheet PPN.CK For Representative Corner Detail.

Michigan Central Station Pre-Set Panning Head And Jamb			
Description	"A" Dim. x "B" Dim.	Extrusion Die #99	
Central Station	2.335 x 2.000	6802	None

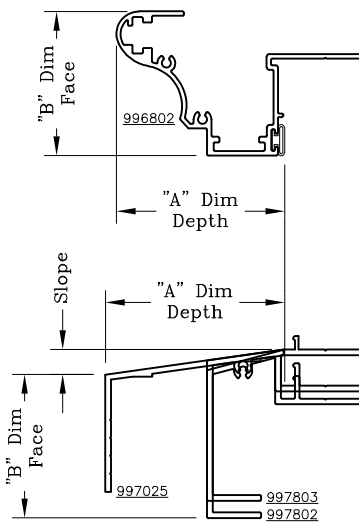

Anderson Extended Pre-Set Panning Head And Jamb			
Description	"A" Dim. x "B" Dim.	Extrusion Die #99	
Anderson Ext.	2.351 x 3.500	6967	None

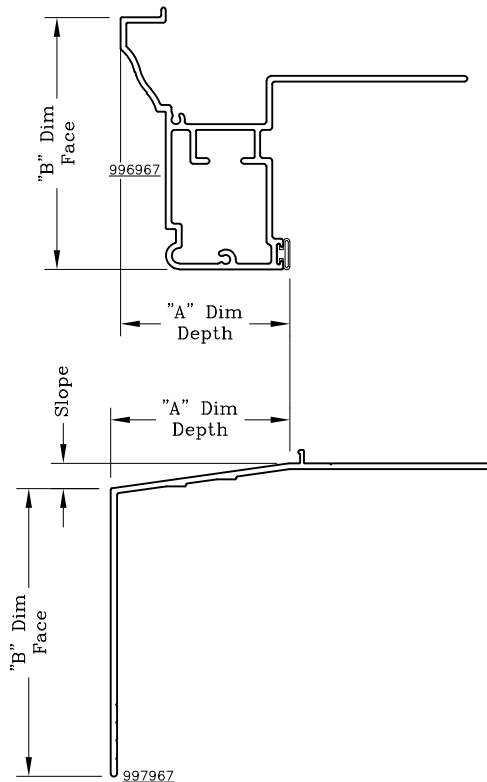

Michigan Central Station Pre-Set Panning Mating Sills			
Description	"A" Dim. x "B" Dim.	Extrusion Die #99	Slope =
#8-1.625S	2.488 x 1.625	7025	.348
Central Station 1	1.078 x 2.188	7802	.147
Central Station 2	1.078 x 1.813	7803	.285

Anderson Extended Pre-Set Panning Mating Sill			
Description	"A" Dim. x "B" Dim.	Extrusion Die #99	Slope =
Anderson Ext.	2.488 x 4.000	7967	.348

Preset Panning Contoured



Series: Accessories Manufacturing Code: PPN33

Drawing 1/2 Scale – For Custom Size Drawing Contact Graham

Note: Sealant Not Shown On Details. Refer To General Installation Instructions.

Note: Pre-Set Panning Requires The Use Of Equal Leg Sill On Window
Some Pre-Set Panning Require The Use Of Mechanical Corner Keys For
Mitered Assembly. Reference Sheet PPN.CK For Representative Corner Detail.

#5-18 With Apron Pre-Set Panning Head And Jambs			
Description	"A" Dim. x "B" Dim.	Extrusion Die #99	
#5-18 3" Apron	3.700 x 2.705	6179	None

Woodward Pre-Set Panning Head And Jambs			
Description	"A" Dim. x "B" Dim.	Extrusion Die #99	
Woodward	2.200 x 2.750	9698	None

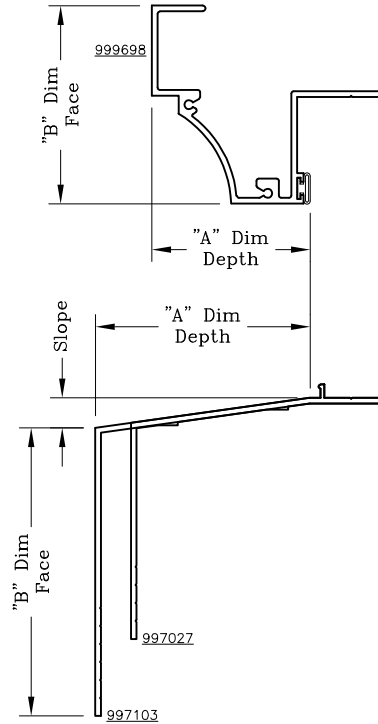
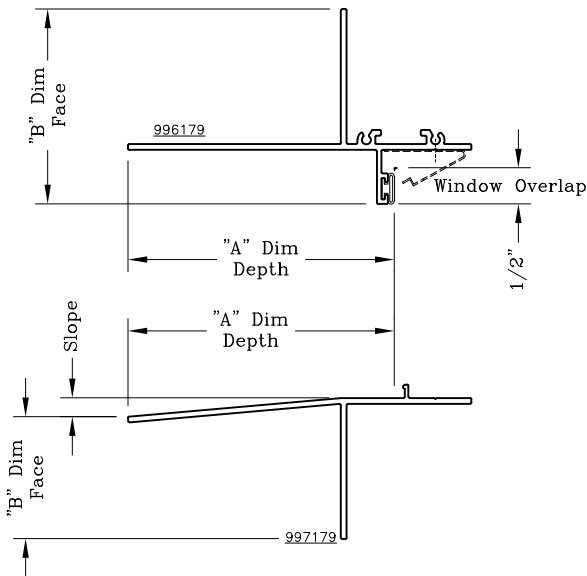

#5-18 With Apron Pre-Set Panning Mating Sills			
Description	"A" Dim. x "B" Dim.	Extrusion Die #99	Slope =
#5-18 3" Apron	3.700 x 1.969	7179	.259

Woodward Pre-Set Panning Mating Sills			
Description	"A" Dim. x "B" Dim.	Extrusion Die #99	Slope =
#8-3S	2.488 x 3.000	7027	.348
Del.-4S	2.984 x 4.000	7103	.415

Graham Architectural Products reserves the right to change, add, cancel, remove or otherwise modify the details illustrated without prior notice.

1551 Mt. Rose Avenue, York, Pennsylvania 17403-2909 717.849.8100 Toll Free: 800/755-6274

0223 - PPN.33

Web Site: www.grahamwindows.com

Preset Panning Contoured



Series: Accessories Manufacturing Code: PPN34

Drawing 1/2 Scale – For Custom Size Drawing Contact Graham

Note: Sealant Not Shown On Details. Refer To General Installation Instructions.

Note: Pre-Set Panning Requires The Use Of Equal Leg Sill On Window
Some Pre-Set Panning Require The Use Of Mechanical Corner Keys For
Mitered Assembly. Reference Sheet PPN.CK For Representative Corner Detail.

Anderson 5” Pre-Set Panning Head And Jamb			
Description	"A" Dim. x "B" Dim.	Extrusion Die #99	
Anderson 5”	2.351 x 5.000	9700	None

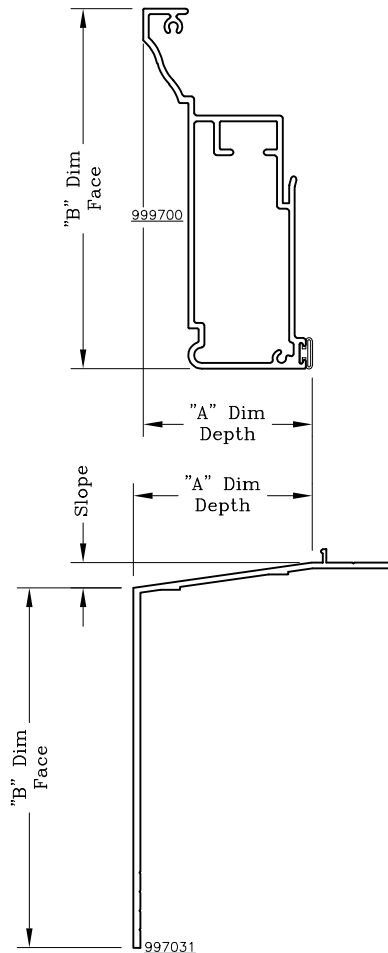

Anderson 5” Pre-Set Panning Mating Sills			
Description	"A" Dim. x "B" Dim.	Extrusion Die #99	Slope =
#8-5S	2.488 x 5.00	7031	.348

Anderson 3.5” Pre-Set Panning Head And Jamb			
Description	"A" Dim. x "B" Dim.	Extrusion Die #99	
Anderson 3.5”	2.351 x 3.500	9710	None

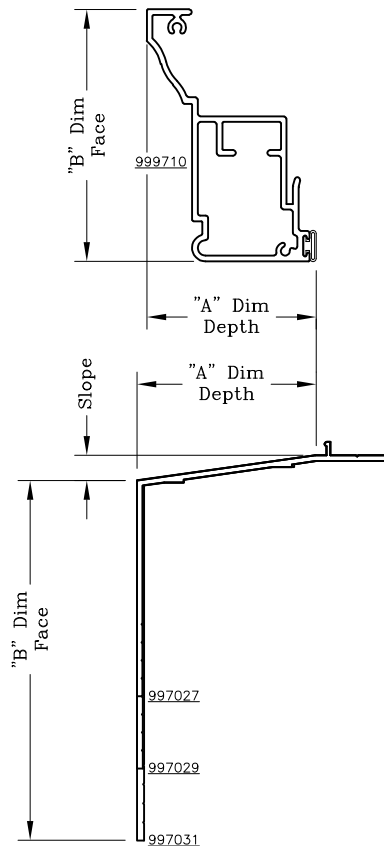

Anderson 3.5” Pre-Set Panning Mating Sills			
Description	"A" Dim. x "B" Dim.	Extrusion Die #99	Slope =
#8-3S	2.488 x 3.000	7027	.348
#8-4S	2.488 x 4.000	7029	.348
#8-5S	2.488 x 5.000	7031	.348

Graham Architectural Products reserves the right to change, add, cancel, remove or otherwise modify the details illustrated without prior notice.

1551 Mt. Rose Avenue, York, Pennsylvania 17403-2909 717.849.8100 Toll Free: 800/755-6274

0223 – PPN.34

Web Site: www.grahamwindows.com

Preset Panning Contoured



Series: Accessories Manufacturing Code: PPN35

Drawing 1/2 Scale – For Custom Size Drawing Contact Graham

Note: Sealant Not Shown On Details. Refer To General Installation Instructions.

Note: Pre-Set Panning Requires The Use Of Equal Leg Sill On Window
Some Pre-Set Panning Require The Use Of Mechanical Corner Keys For
Mitered Assembly. Reference Sheet PPN.CK For Representative Corner Detail.

1616 Walnut Pre-Set Panning Head And Jambs			
Description	"A" Dim. x "B" Dim.	Extrusion Die #99	
1616 Walnut	1.500 x 1.625	9883	None

Innovative Living Pre-Set Panning Head And Jambs			
Description	"A" Dim. x "B" Dim.	Extrusion Die #99	
Innovative Living	3.468 x 2.875	6220	None

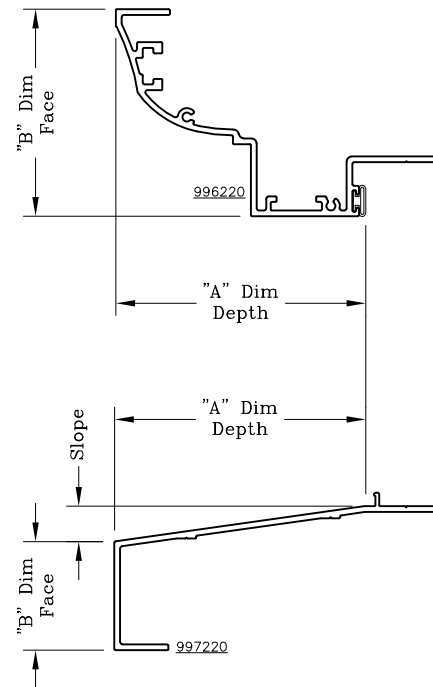
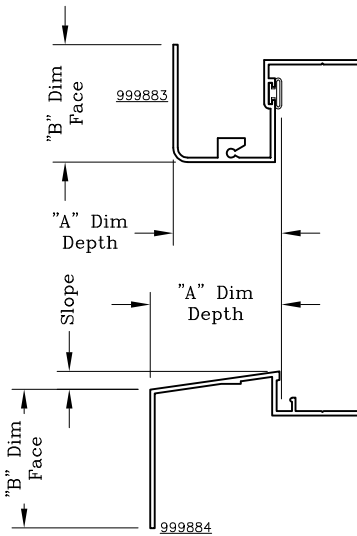

1616 Walnut Pre-Set Panning Mating Sills			
Description	"A" Dim. x "B" Dim.	Extrusion Die #99	Slope =
1616 Walnut	1.824 x 1.924	9884	.252

Innovative Living Pre-Set Panning Mating Sills			
Description	"A" Dim. x "B" Dim.	Extrusion Die #99	Slope =
Innovative Living	3.488 x 1.509	7220	.491

Preset Panning Contoured



Series: Accessories Manufacturing Code: PPN36

Drawing 1/2 Scale – For Custom Size Drawing Contact Graham

Note: Sealant Not Shown On Details. Refer To General Installation Instructions.

Note: Pre-Set Panning Requires The Use Of Equal Leg Sill On Window
Some Pre-Set Panning Require The Use Of Mechanical Corner Keys For
Mitered Assembly. Reference Sheet PPN.CK For Representative Corner Detail.

Cleveland Pre-Set Panning Head And Jambs			
Description	"A" Dim. x "B" Dim.	Extrusion Die #99	
Cleveland	3.343 x 3.875	6152	None

Pullman Pre-Set Panning Head And Jambs			
Description	"A" Dim. x "B" Dim.	Extrusion Die #99	
Pullman	4.000 x 4.000	6182	None

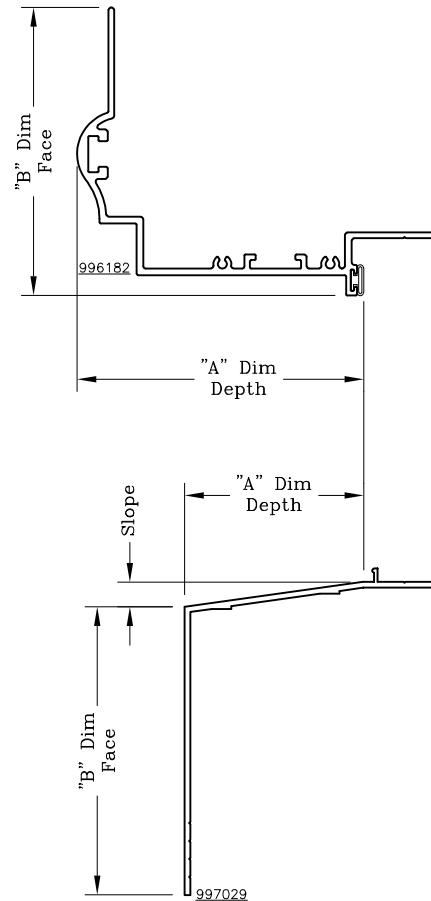
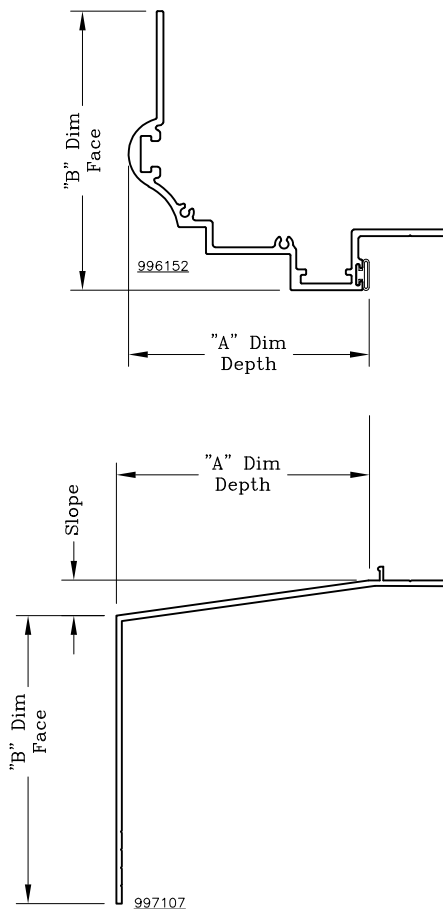

Cleveland Pre-Set Panning Mating Sills			
Description	"A" Dim. x "B" Dim.	Extrusion Die #99	Slope =
3.5 x 4.0	3.500 x 4.000	7107	.493

Pullman Pre-Set Panning Mating Sills			
Description	"A" Dim. x "B" Dim.	Extrusion Die #99	Slope =
#8-4S	2.488 x 4.000	7029	.348

Graham Architectural Products reserves the right to change, add, cancel, remove or otherwise modify the details illustrated without prior notice.

1551 Mt. Rose Avenue, York, Pennsylvania 17403-2909 717.849.8100 Toll Free: 800/755-6274

0223 – PPN.36

Web Site: www.grahamwindows.com

Preset Panning Contoured



Series: Accessories Manufacturing Code: PPN37

Drawing 1/2 Scale – For Custom Size Drawing Contact Graham

Note: Sealant Not Shown On Details. Refer To General Installation Instructions.

Note: Pre-Set Panning Requires The Use Of Equal Leg Sill On Window
Some Pre-Set Panning Require The Use Of Mechanical Corner Keys For
Mitered Assembly. Reference Sheet PPN.CK For Representative Corner Detail.

Belden Stratford Ph2 Pre-Set Panning Head And Jambs			
Description	"A" Dim. x "B" Dim.	Extrusion Die #99	
Belden Stratford	3.965 x 2.812	6218	None

Belden Stratford Ph2 Pre-Set Panning Head And Jambs			
Description	"A" Dim. x "B" Dim.	Extrusion Die #99	
Belden Stratford	3.558 x 3.547	6222	None

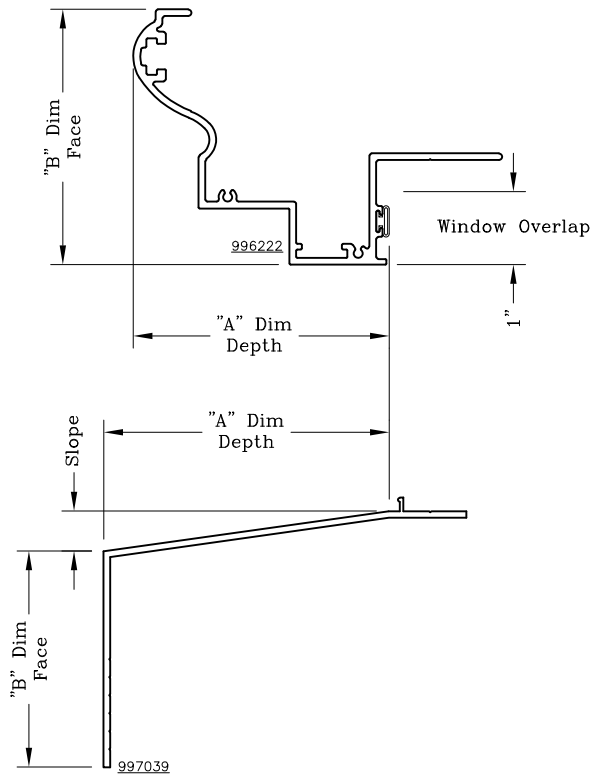
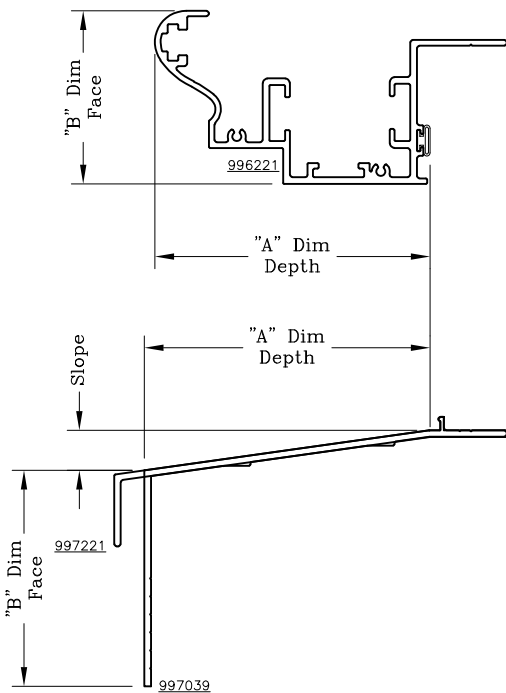

Belden Stratford Ph2 Pre-Set Panning Mating Sills			
Description	"A" Dim. x "B" Dim.	Extrusion Die #99	Slope =
#3-3S	3.969 x 3.000	7039	.556
Belden Stratford	4.386 x 1.000	7221	.614

Belden Stratford Ph2 Pre-Set Panning Mating Sill			
Description	"A" Dim. x "B" Dim.	Extrusion Die #99	Slope =
#3-3S	3.969 x 3.000	7039	.556

Graham Architectural Products reserves the right to change, add, cancel, remove or otherwise modify the details illustrated without prior notice.

1551 Mt. Rose Avenue, York, Pennsylvania 17403-2909 717.849.8100 Toll Free: 800/755-6274

0223 – PPN.37

Web Site: www.grahamwindows.com

Preset Panning Contoured



Series: Accessories Manufacturing Code: PPN38

Drawing 1/2 Scale – For Custom Size Drawing Contact Graham

Note: Sealant Not Shown On Details. Refer To General Installation Instructions.

Note: Pre-Set Panning Requires The Use Of Equal Leg Sill On Window
Some Pre-Set Panning Require The Use Of Mechanical Corner Keys For
Mitered Assembly. Reference Sheet PPN.CK For Representative Corner Detail.

Cambria #1 Pre-Set Panning Head And Jambs			
Description	"A" Dim. x "B" Dim.	Extrusion Die #99	
Cambria #1	3.000 x 2.233	6184	None

Cambria #2 Pre-Set Panning Head And Jambs			
Description	"A" Dim. x "B" Dim.	Extrusion Die #99	
Cambria #2	2.922 x 2.203	6185	None

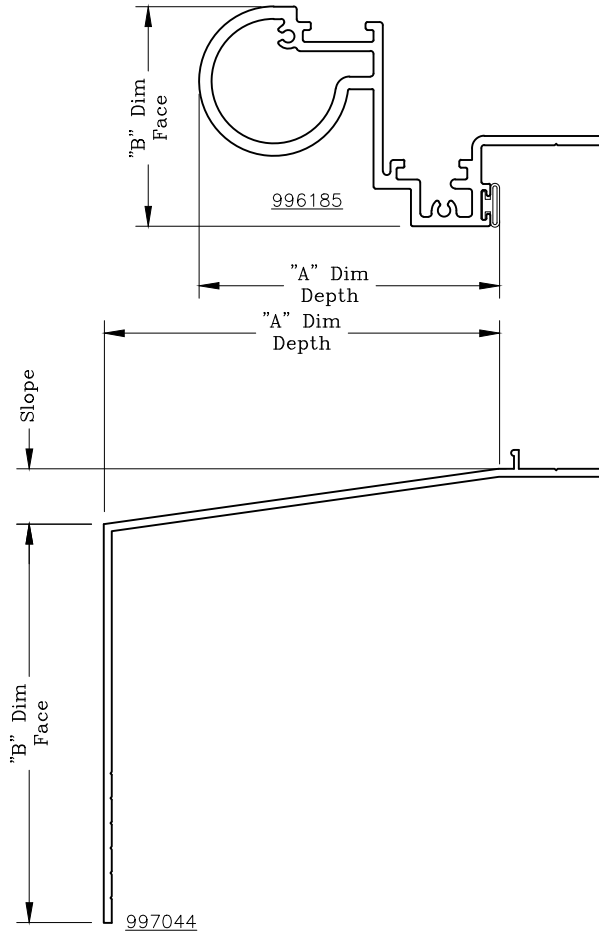
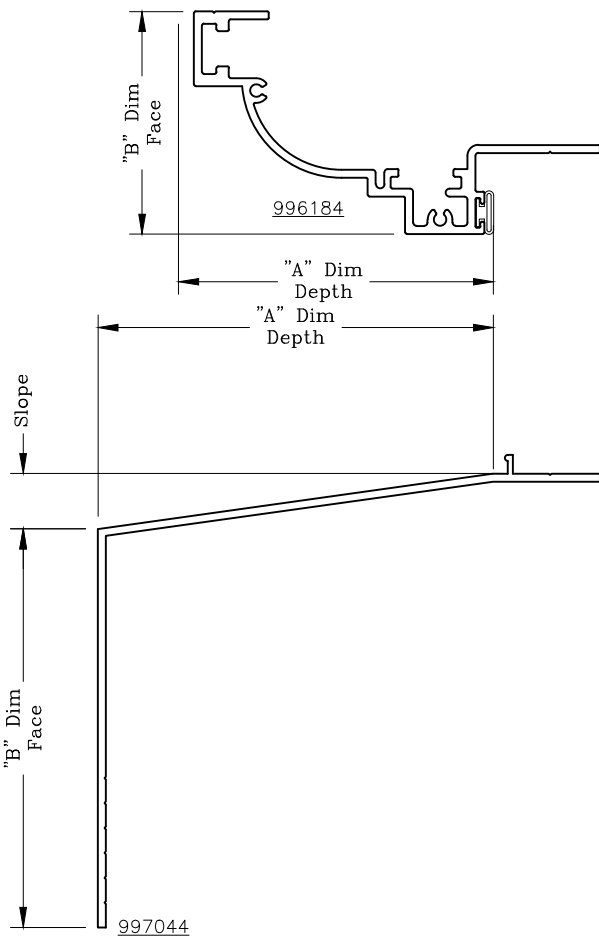

Cambria #1& #2 Pre-Set Panning Mating Sills			
Description	"A" Dim. x "B" Dim.	Extrusion Die #99	Slope =
#3-4S	3.969 x 4.000	7044	.556

Graham Architectural Products reserves the right to change, add, cancel, remove or otherwise modify the details illustrated without prior notice.

1551 Mt. Rose Avenue, York, Pennsylvania 17403-2909 717.849.8100 Toll Free: 800/755-6274

0624 – PPN.38

Web Site: www.grahamwindows.com

Preset Panning Contoured



Series: Accessories Manufacturing Code: PPN40

Drawing 1/2 Scale – For Custom Size Drawing Contact Graham

Note: Sealant Not Shown On Details. Refer To General Installation Instructions.

Note: Pre-Set Panning Requires The Use Of Equal Leg Sill On Window
Some Pre-Set Panning Require The Use Of Mechanical Corner Keys For
Mitered Assembly. Reference Sheet PPN.CK For Representative Corner Detail.

Marketway 2 Pre-Set Panning Head And Jambs			
Description	"A" Dim. x "B" Dim.	Extrusion Die #99	
Marketway 2	3.070 x 1.875	6110	None

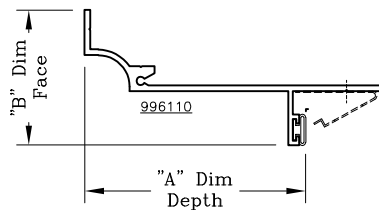

No Current Sill Panning Associated
Contact Graham For Sill Panning Options

Courier Square 1 Pre-Set Panning Head And Jambs			
Description	"A" Dim. x "B" Dim.	Extrusion Die #99	
Courier Square 1	2.218 x 2.000	6144	None

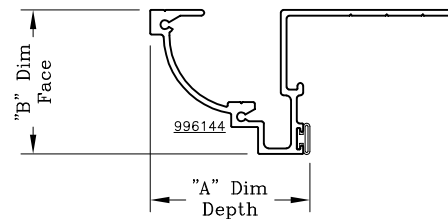

No Current Sill Panning Associated
Contact Graham For Sill Panning Options

1600 Callowhill Pre-Set Panning Head And Jambs			
Description	"A" Dim. x "B" Dim.	Extrusion Die #99	
1600 Callowhill	2.156 x 6.000	6180	None

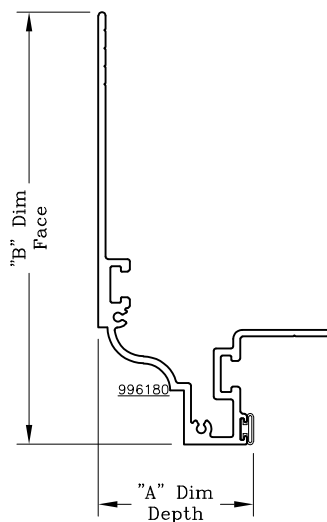

No Current Sill Panning Associated
Contact Graham For Sill Panning Options

Graham Architectural Products reserves the right to change, add, cancel, remove or otherwise modify the details illustrated without prior notice.

1551 Mt. Rose Avenue, York, Pennsylvania 17403-2909 717.849.8100 Toll Free: 800/755-6274

0223 – PPN.40

Web Site: www.grahamwindows.com

Preset Panning Sills



Series: Accessories Manufacturing Code: PPN41

Drawing 1/2 Scale – For Custom Size Drawing Contact Graham

Note: Sealant Not Shown On Details. Refer To General Installation Instructions.

Note: Pre-Set Panning Requires The Use Of Equal Leg Sill On Window
Some Pre-Set Panning Require The Use Of Mechanical Corner Keys For
Mitered Assembly. Reference Sheet PPN.CK For Representative Corner Detail.

Reading Outlet Pre-Set Panning Mating Sills			
Description	"A" Dim. x "B" Dim.	Extrusion Die #99	Slope =
Reading Outlet	2.980 x 1.458	6965	.417

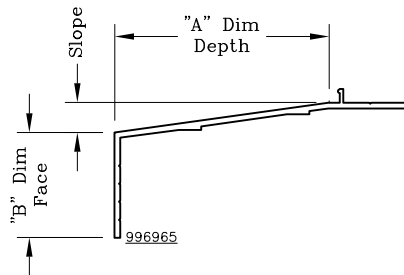

No Current Jamb Panning Associated
Contact Graham For Jamb Panning Options

Miami Psyche Pre-Set Panning Mating Sills			
Description	"A" Dim. x "B" Dim.	Extrusion Die #99	Slope =
Miami Psyche	3.230 x .375	7988	.455

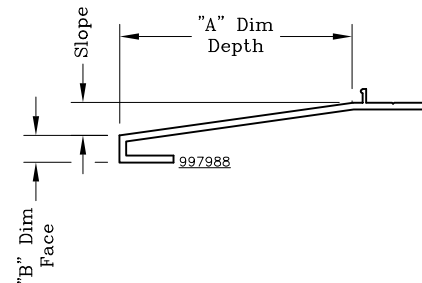

No Current Jamb Panning Associated
Contact Graham For Jamb Panning Options

Preset Panning Corner Key Representation



Series: Accessories Manufacturing Code:

Drawing 1/2 Scale – For Custom Size Drawing Contact Graham

Note: Sealant Not Shown On Details. Refer To General Installation Instructions.

Note: Pre-Set Panning Requires The Use Of Equal Leg Sill On Window

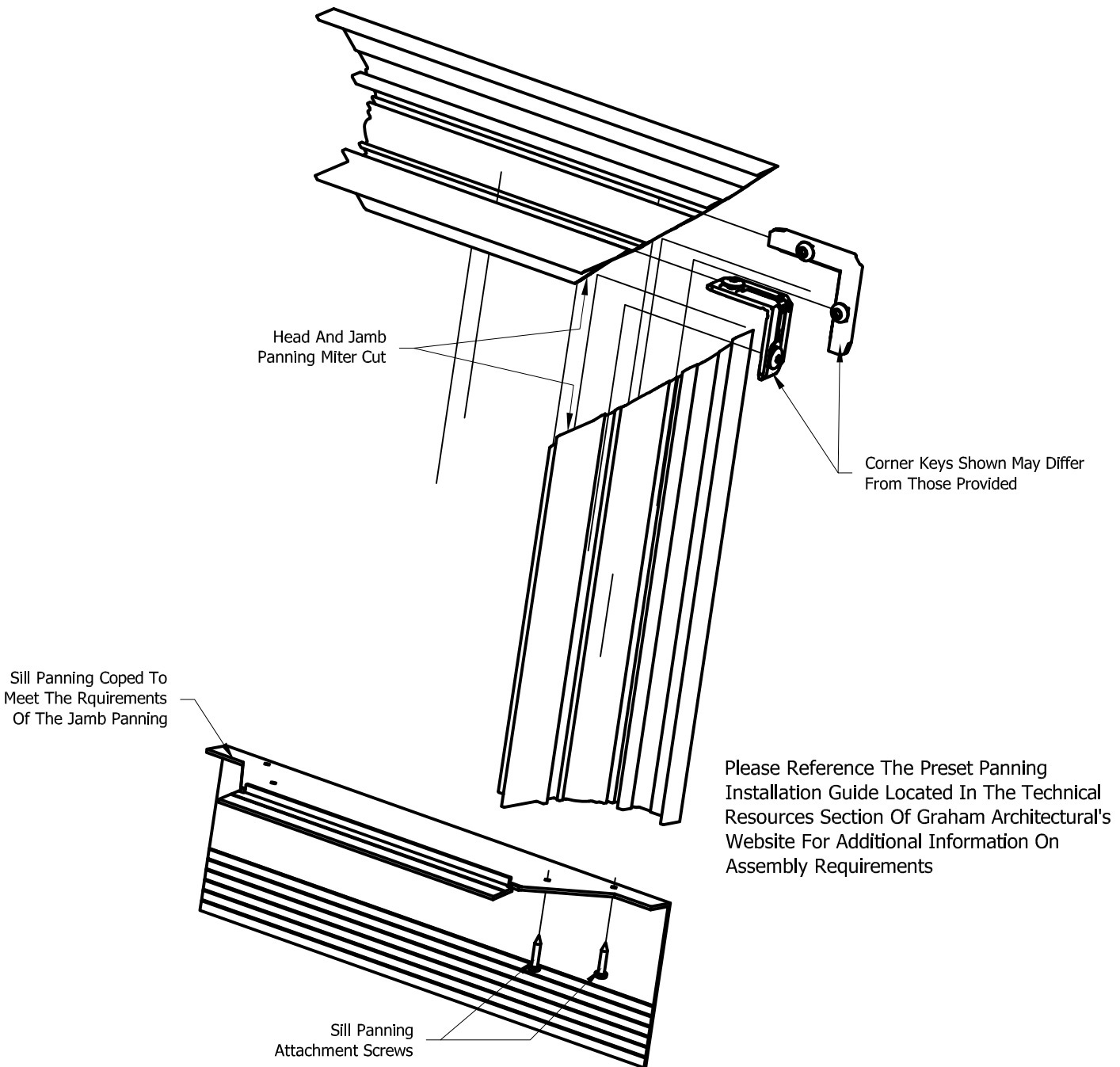

Graham Architectural Products reserves the right to change, add, cancel, remove or otherwise modify the details illustrated without prior notice.

1551 Mt. Rose Avenue, York, Pennsylvania 17403-2909 717.849.8100 Toll Free: 800/755-6274

0223 – PPN.CK

Web Site: www.grahamwindows.com