

Accessories – 3 1/4" Products



Series: Accessories Manufacturing Code: AC03A

Drawing 1/2 Scale – For Custom Size Drawing Contact Graham

Note: Sealant Not Shown On Details. Refer To General Installation Instructions.

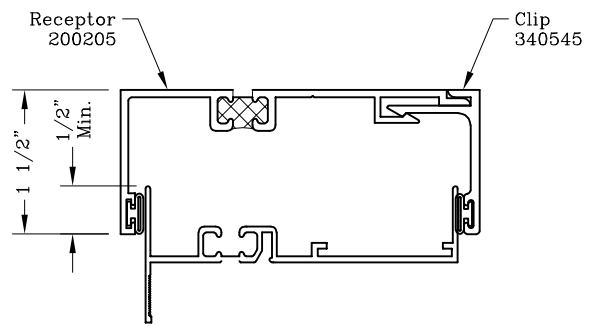
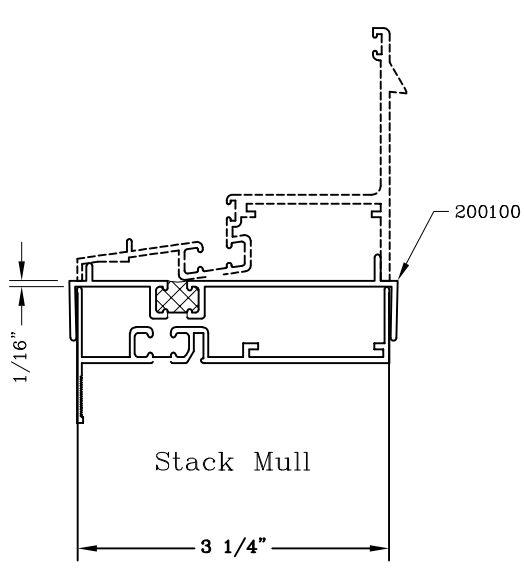

Receptor & Clip

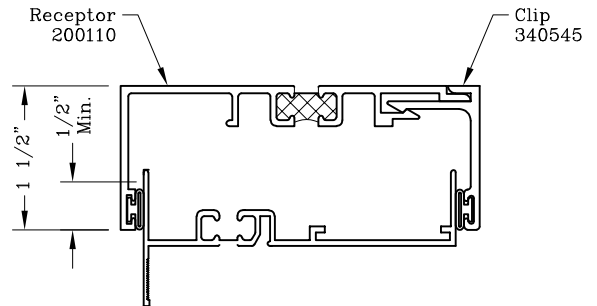

Receptor & Clip

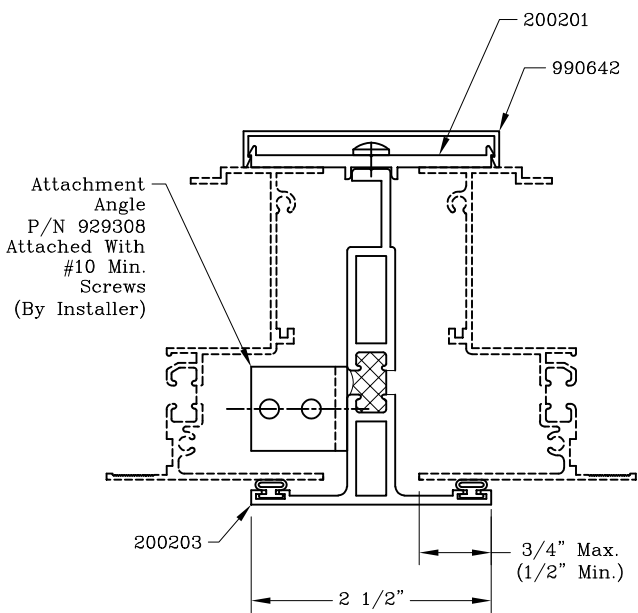

3 Piece Mull

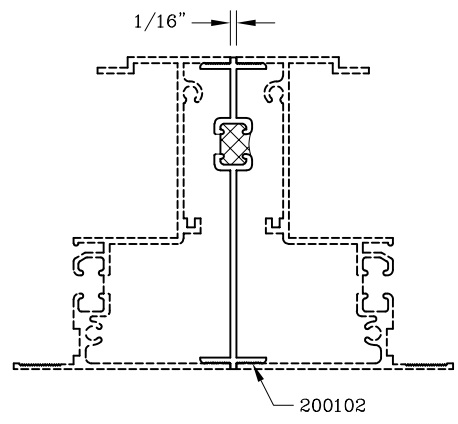

1/16" Mull

Accessories – 3 1/4” Products



Series: Accessories Manufacturing Code: AC03B

Drawing 1/2 Scale – For Custom Size Drawing Contact Graham

Note: Sealant Not Shown On Details. Refer To General Installation Instructions.

Note: Not All Options Are Shown, Contact Graham For Other Options.

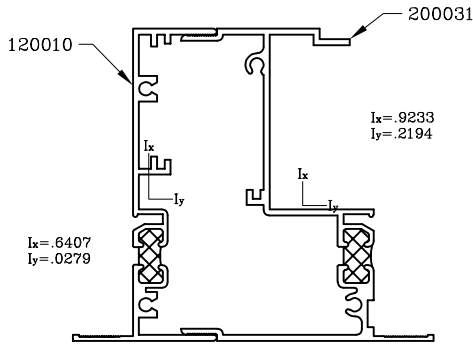

1200 Series With 2000 Series

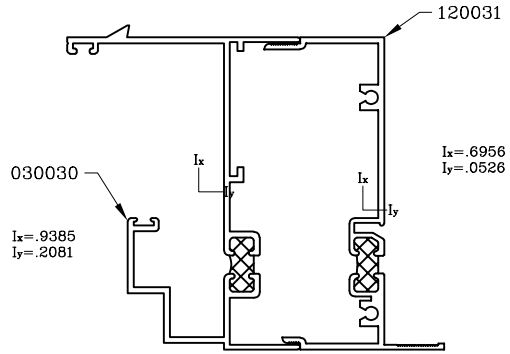

0300 Series With 1200 Series

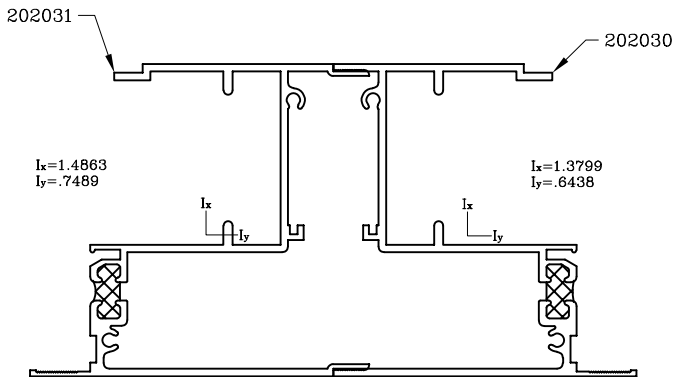

2000 Series With 2000 Series

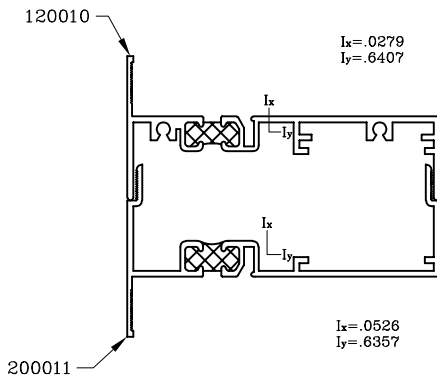

1200 Series With 2000 Series

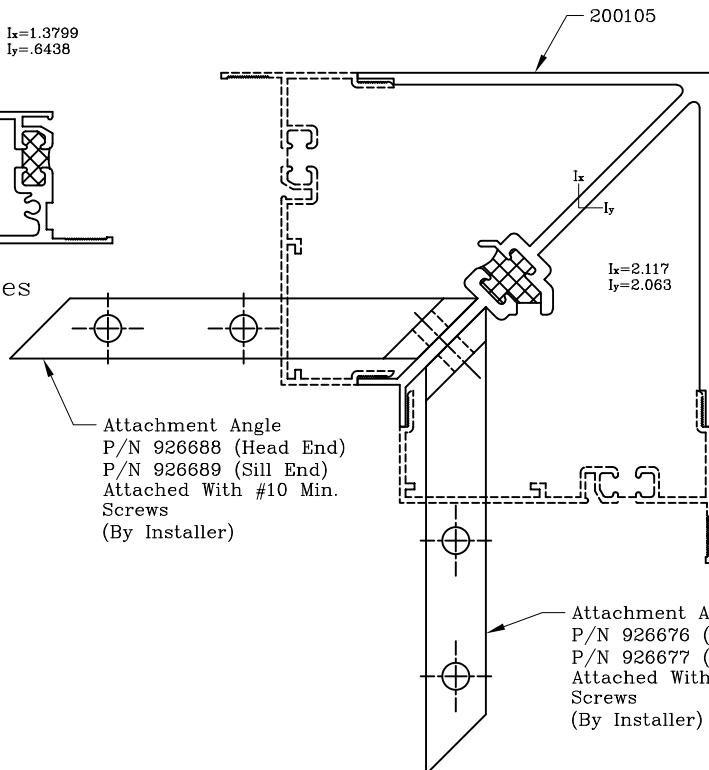

90° Corner Mullion

Graham Architectural Products reserves the right to change, add, cancel, remove or otherwise modify the details illustrated without prior notice.

1551 Mt. Rose Avenue, York, Pennsylvania 17403-2909 717.849.8100 Toll Free: 800/755-6274

0223 – AC.03B

Web Site: www.grahamwindows.com

Accessories – 3 1/4” Products



Series: Accessories Manufacturing Code: AC03C

Drawing 1/2 Scale – For Custom Size Drawing Contact Graham

Note: Sealant Not Shown On Details. Refer To General Installation Instructions.

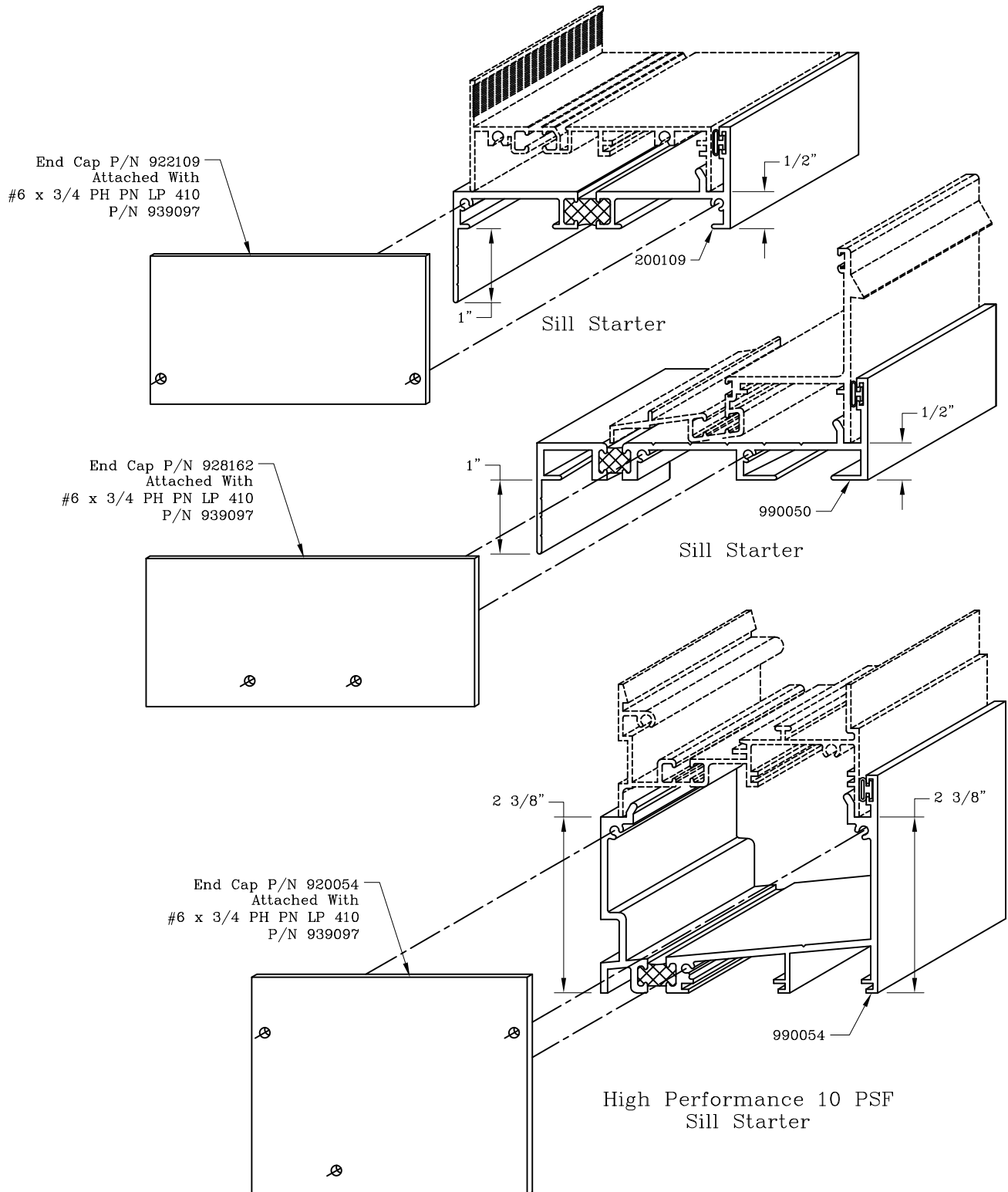

Graham Architectural Products reserves the right to change, add, cancel, remove or otherwise modify the details illustrated without prior notice.

1551 Mt. Rose Avenue, York, Pennsylvania 17403-2909 717.849.8100 Toll Free: 800/755-6274

0223 – AC.03C

Web Site: www.grahamwindows.com

Accessories – 3 1/4” Products Self-Mull Options



Series: Accessories Manufacturing Code: AC03D

Drawing 1/2 Scale – For Custom Size Drawing Contact Graham

Note: Sealant Not Shown On Details. Refer To General Installation Instructions.

Note: Not All Options Are Shown, Contact Graham For Other Options.

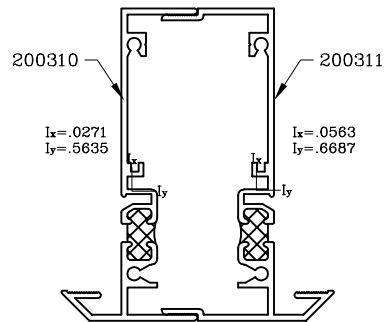

1200 Series With 1200 Series

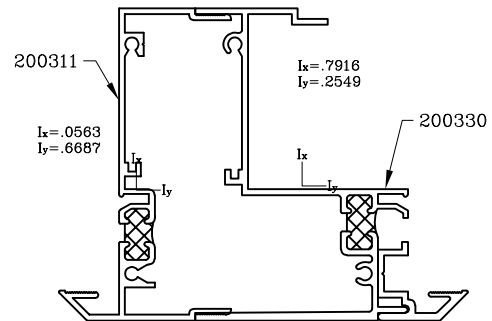

1200 Series With 2000 Series

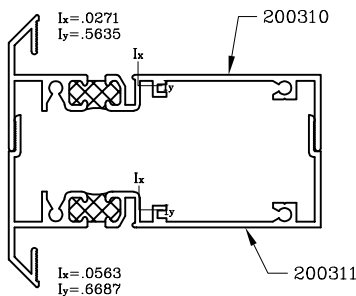

1200 Series With 2000 Series

Graham Architectural Products reserves the right to change, add, cancel, remove or otherwise modify the details illustrated without prior notice.

1551 Mt. Rose Avenue, York, Pennsylvania 17403-2909 717.849.8100 Toll Free: 800/755-6274

0223 – AC.03D

Web Site: www.grahamwindows.com

Accessories – 3 1/4" Products



Series: Accessories Manufacturing Code: AC03E

Drawing 1/2 Scale – For Custom Size Drawing Contact Graham

Note: Sealant Not Shown On Details. Refer To General Installation Instructions.

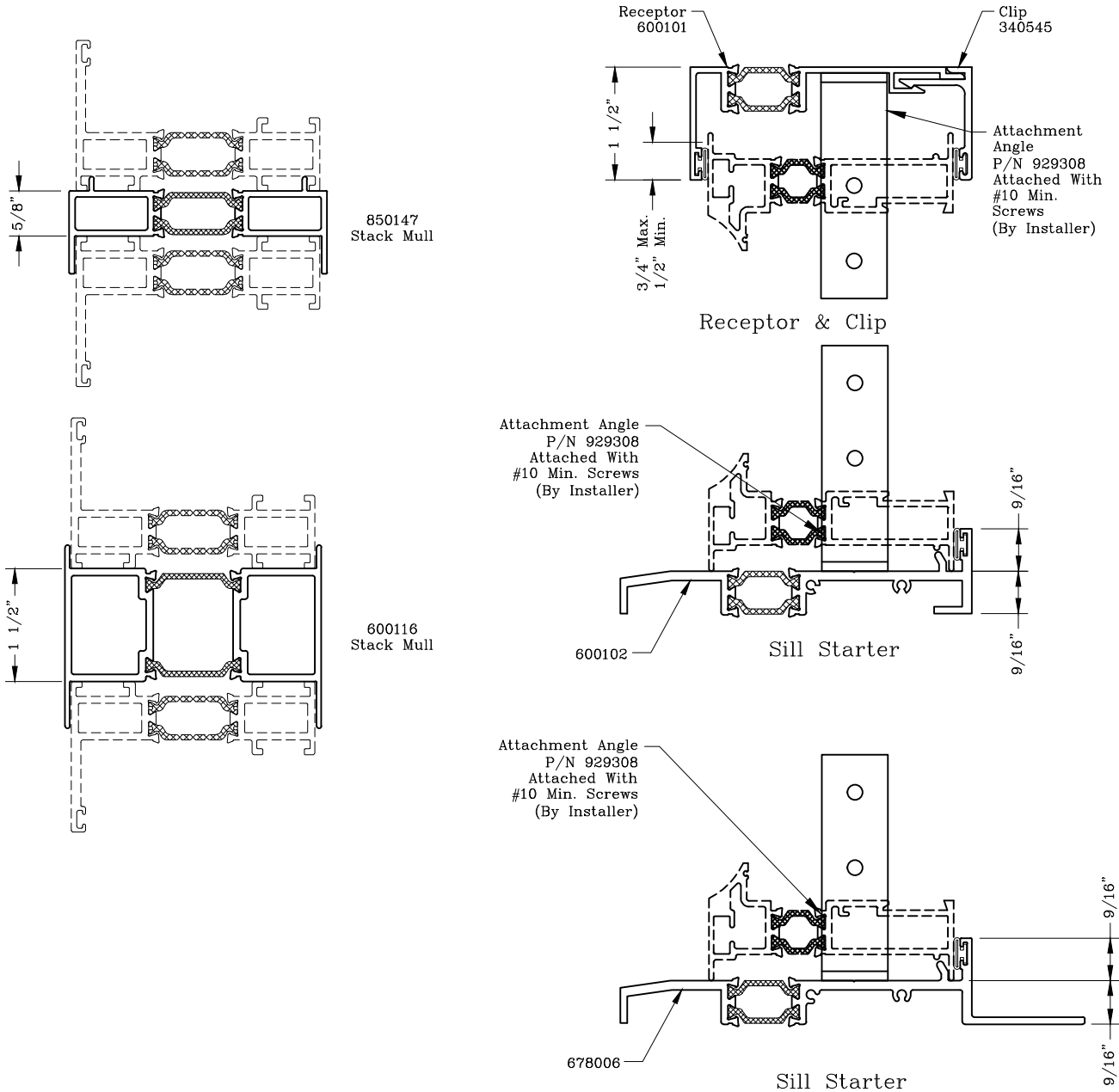

Accessories - 3 1/4" Products



Series: Accessories Manufacturing Code: AC03F

Drawing 1/2 Scale - For Custom Size Drawing Contact Graham

Note: Sealant Not Shown On Details. Refer To General Installation Instructions.

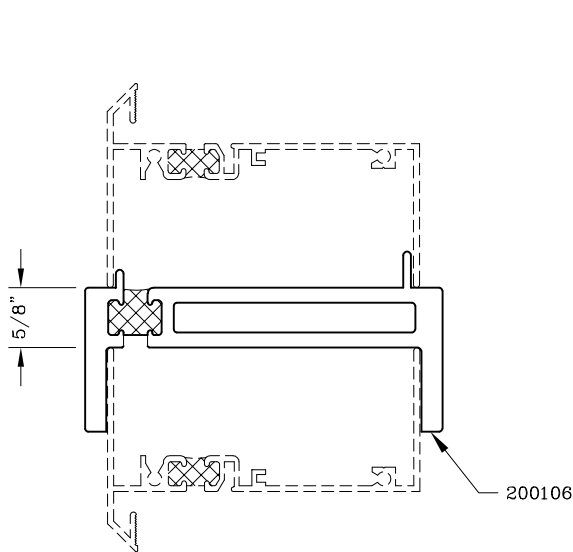

Stack Mull - Heavy Wall

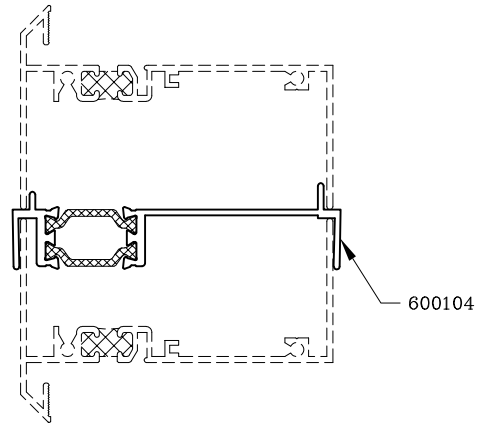

Stack Mull - Struttet

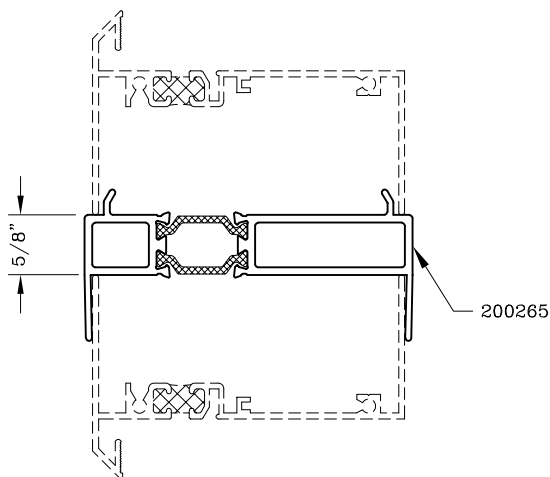

Stack Mull - Struttet

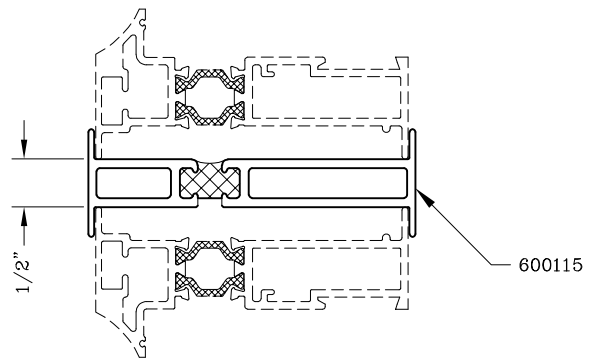

Stack Mull - SR6700

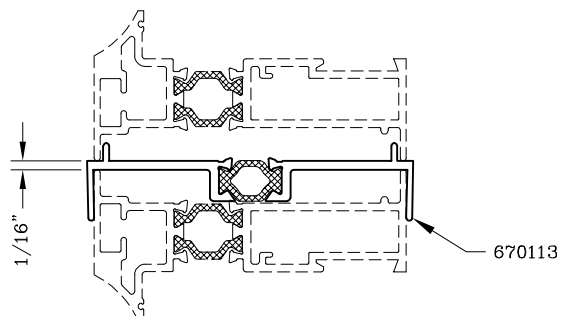

Stack Mull - SR6700

Graham Architectural Products reserves the right to change, add, cancel, remove or otherwise modify the details illustrated without prior notice.

1551 Mt. Rose Avenue, York, Pennsylvania 17403-2909 717.849.8100 Toll Free: 800/755-6274

0223 - AC.03F

Web Site: www.grahamwindows.com

Accessories – 3 1/4" Products



Series: Accessories Manufacturing Code: AC03G

Drawing 1/2 Scale – For Custom Size Drawing Contact Graham

Note: Sealant Not Shown On Details. Refer To General Installation Instructions.

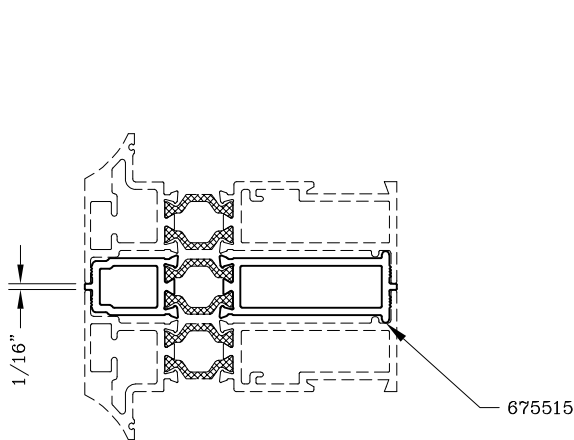

1/8" Mull - SR6700 Strutted

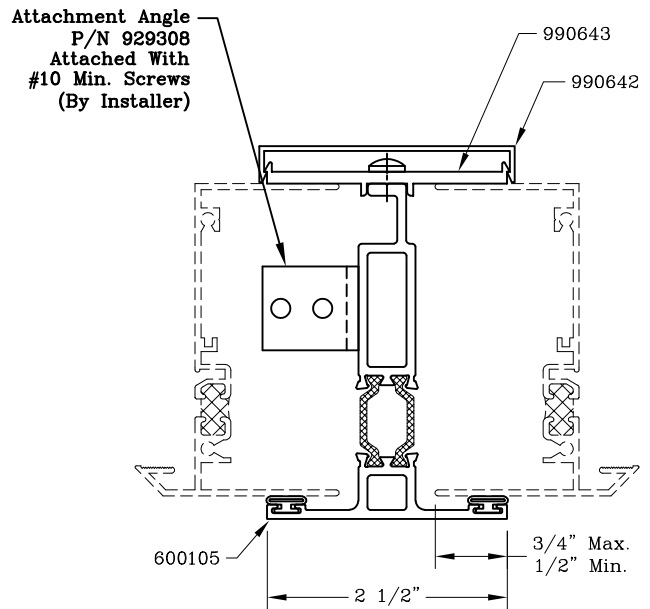

3 Piece Mull

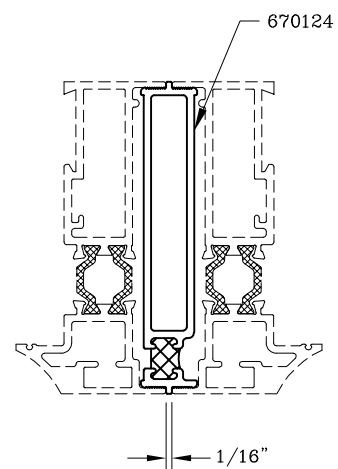
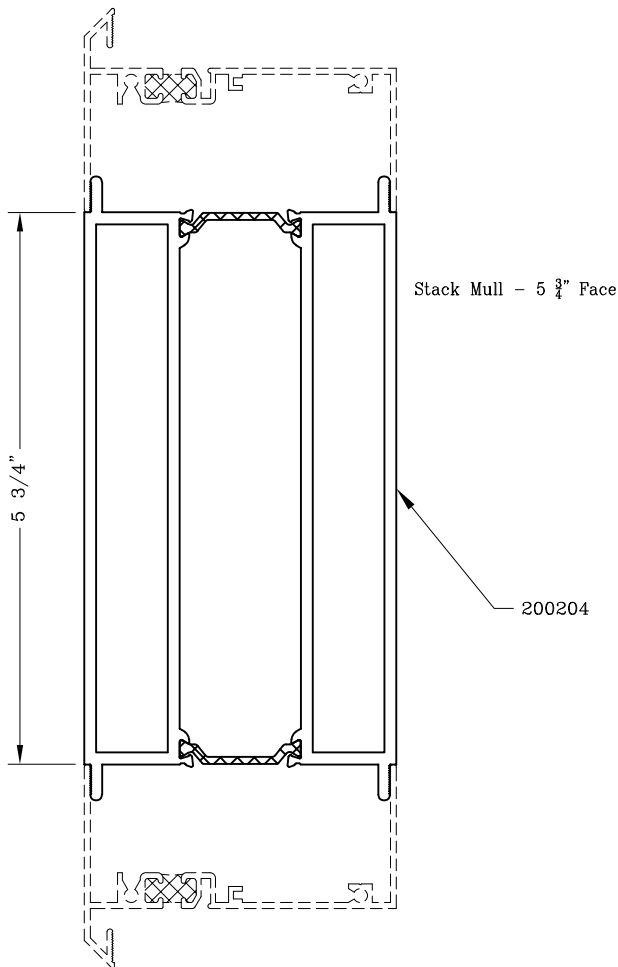

1/8" Mullion - SR6700

Graham Architectural Products reserves the right to change, add, cancel, remove or otherwise modify the details illustrated without prior notice.

1551 Mt. Rose Avenue, York, Pennsylvania 17403-2909 717.849.8100 Toll Free: 800/755-6274

0223 - AC.03G

Web Site: www.grahamwindows.com

Accessories - 3 1/4" Products



Series: Accessories Manufacturing Code: AC03H

Drawing 1/2 Scale - For Custom Size Drawing Contact Graham

Note: Sealant Not Shown On Details. Refer To General Installation Instructions.

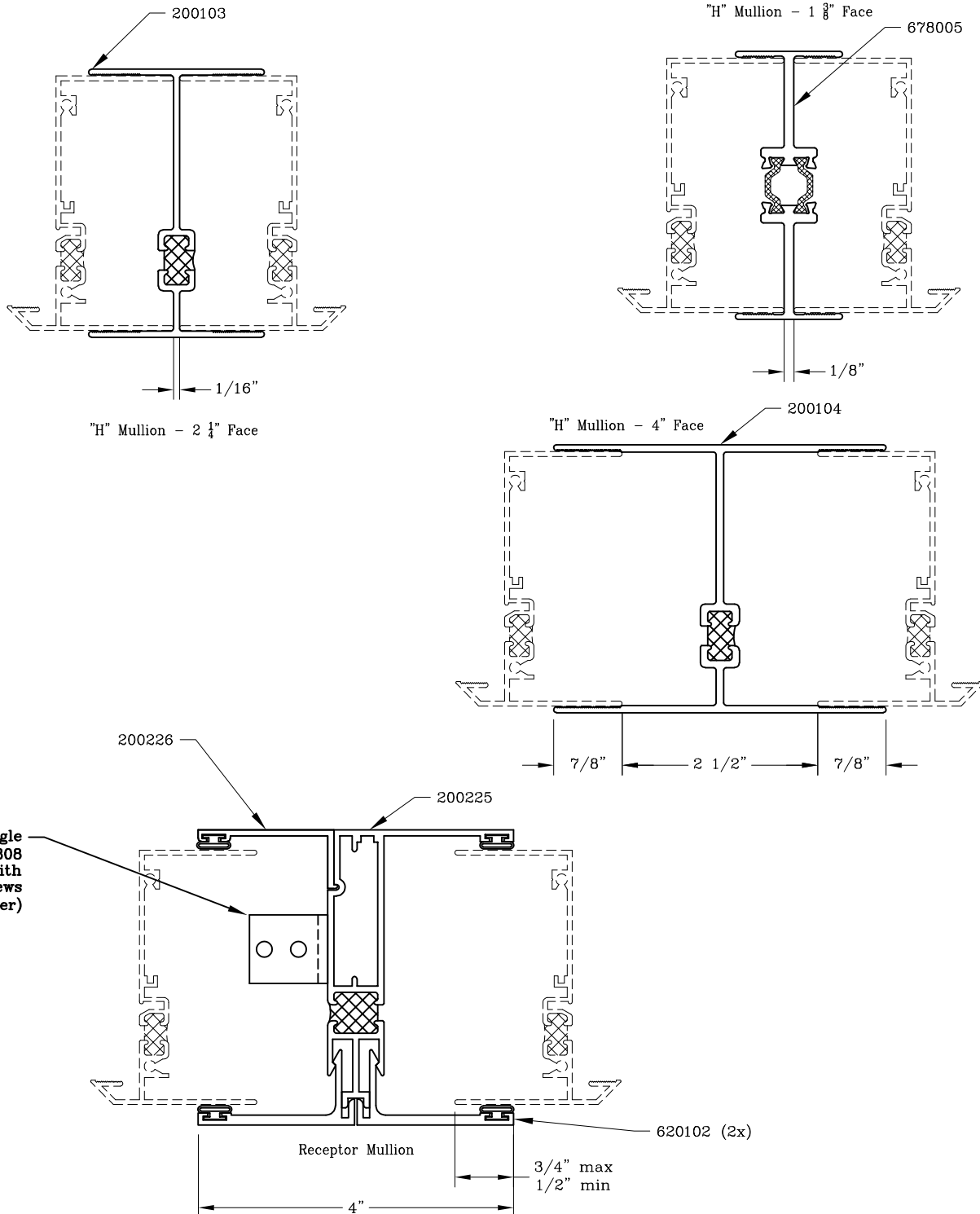

Attachment Angle
P/N 929308
Attached With
#10 Min. Screws
(By Installer)

Graham Architectural Products reserves the right to change, add, cancel, remove or otherwise modify the details illustrated without prior notice.

1551 Mt. Rose Avenue, York, Pennsylvania 17403-2909 717.849.8100 Toll Free: 800/755-6274

0223 - AC.03H

Web Site: www.grahamwindows.com

Accessories - 3 1/4" Products



Series: Accessories Manufacturing Code: AC03I

Drawing 1/2 Scale - For Custom Size Drawing Contact Graham

Note: Sealant Not Shown On Details. Refer To General Installation Instructions.

Vertical Tube Mull SR6700 - 6 1/4"

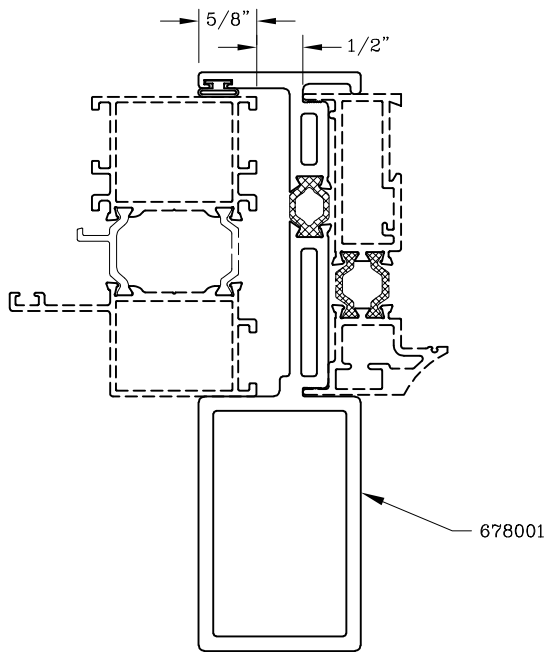

Transition Mull SR6700 - GT7700

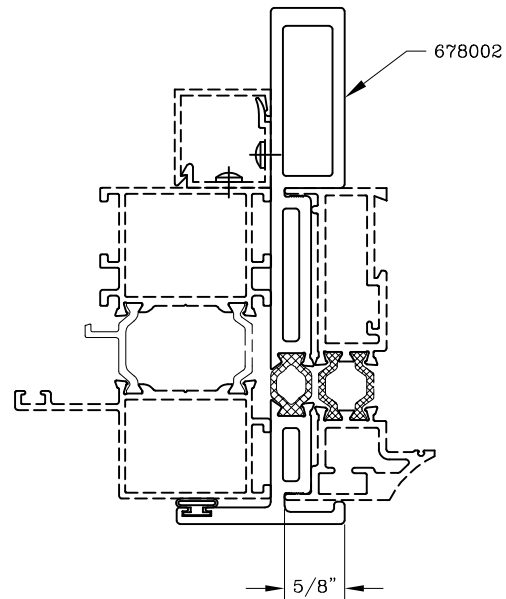

Vertical Tube Mull SR6700 - 4 7/8"

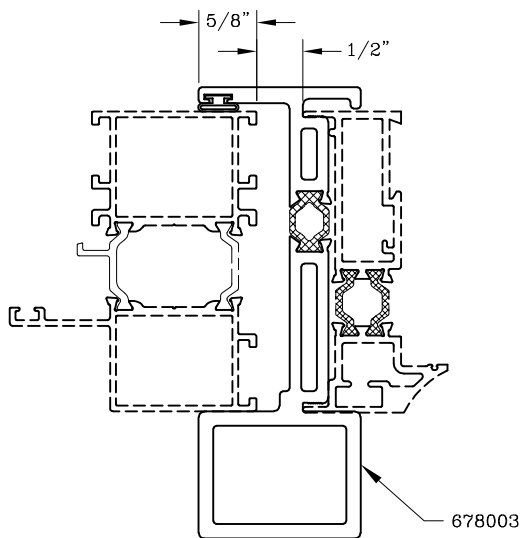

Transition Mull SR6700 - GT7700

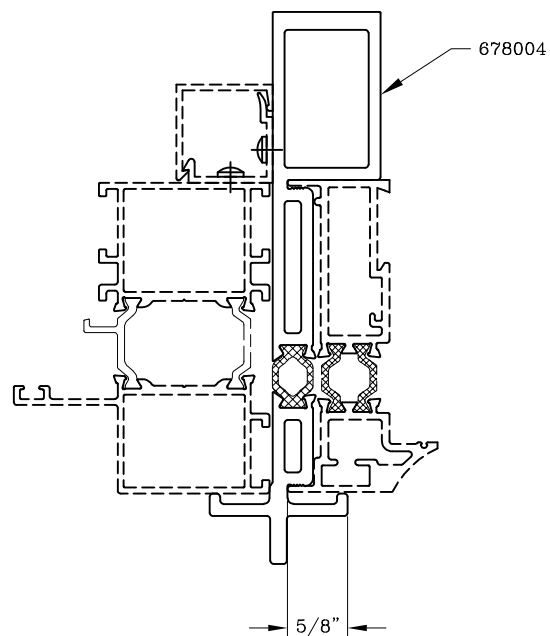

Graham Architectural Products reserves the right to change, add, cancel, remove or otherwise modify the details illustrated without prior notice.

1551 Mt. Rose Avenue, York, Pennsylvania 17403-2909 717.849.8100 Toll Free: 800/755-6274

0223 - AC.03I

Web Site: www.grahamwindows.com

Accessories - 3 1/4" Products



Series: Accessories Manufacturing Code: AC03J

Drawing 1/2 Scale - For Custom Size Drawing Contact Graham

Note: Sealant Not Shown On Details. Refer To General Installation Instructions.

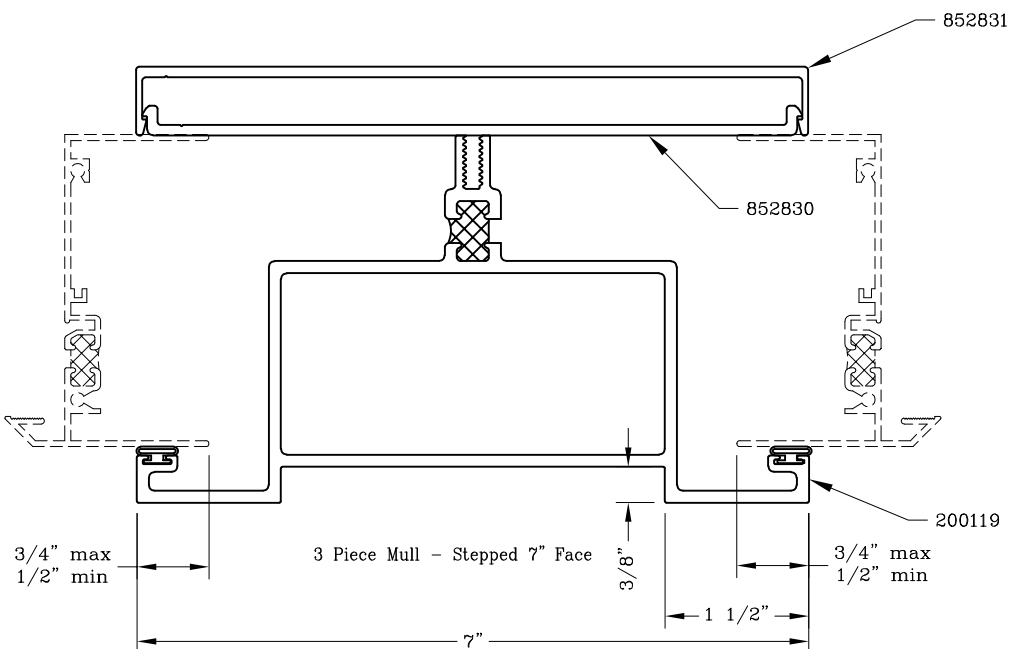
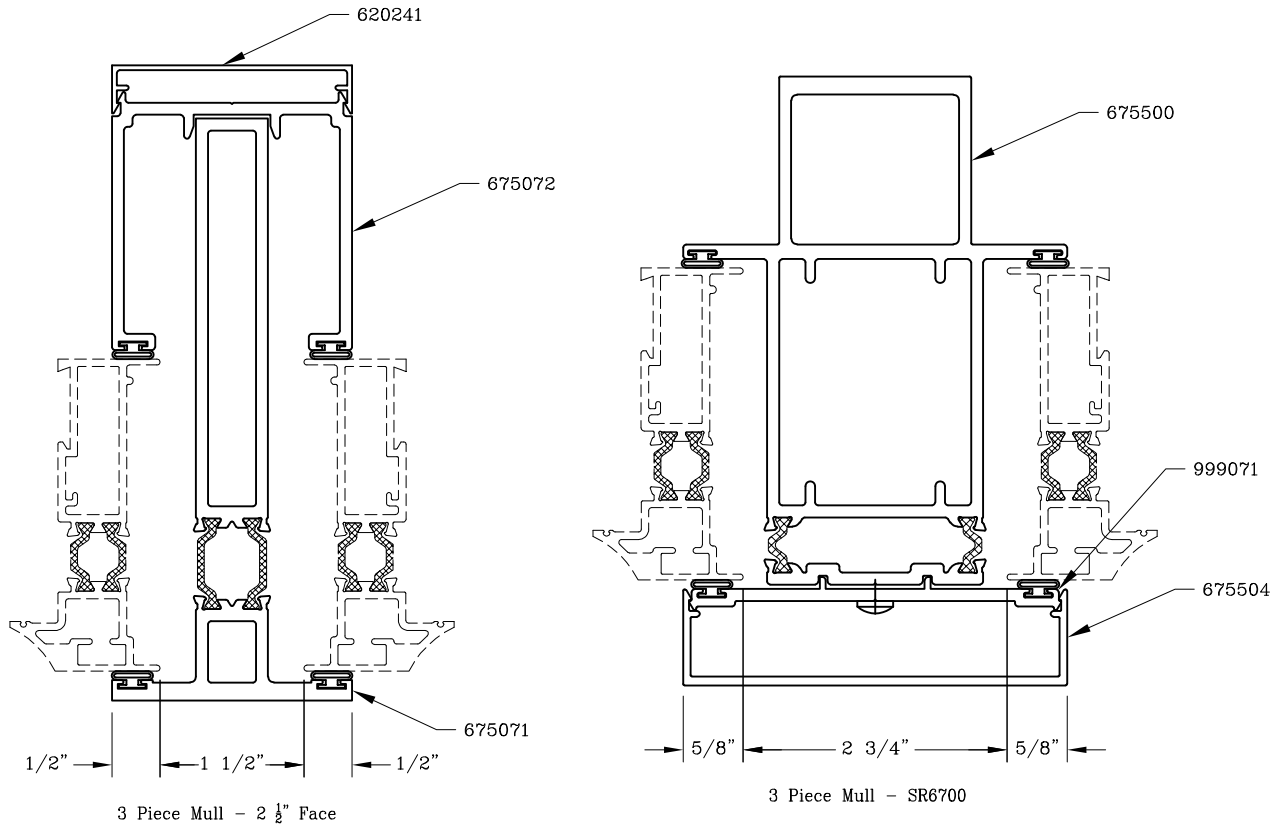

Accessories - 3 1/4" Products



Series: Accessories Manufacturing Code: AC03K

Drawing 1/2 Scale - For Custom Size Drawing Contact Graham

Note: Sealant Not Shown On Details. Refer To General Installation Instructions.

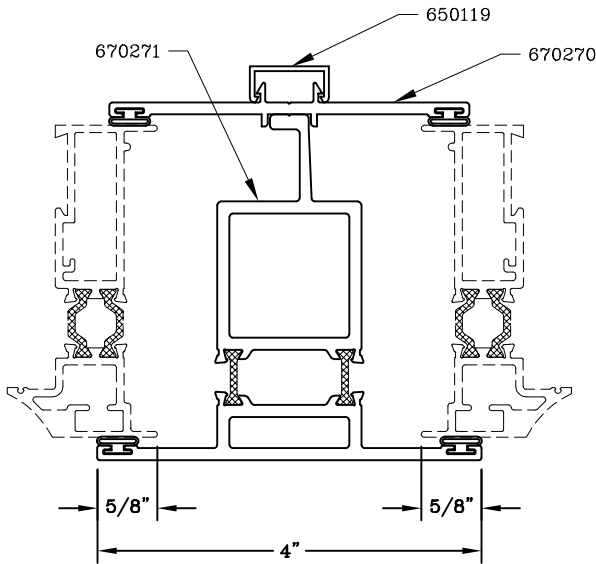

Vertical Mullion - 4" Face

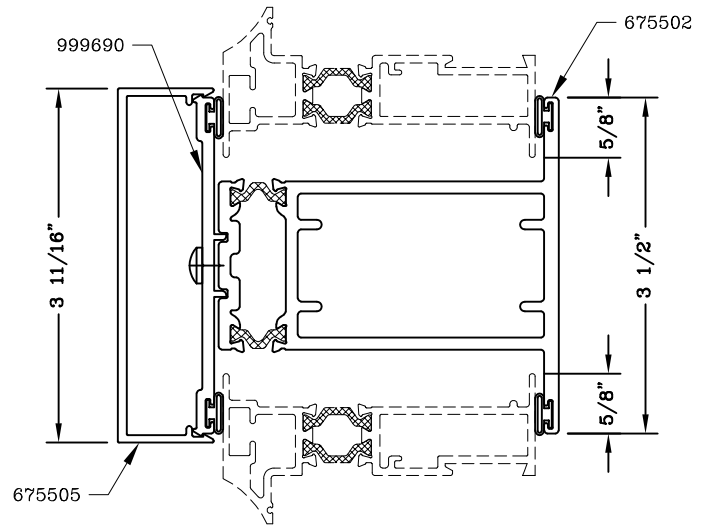

Horizontal Mullion

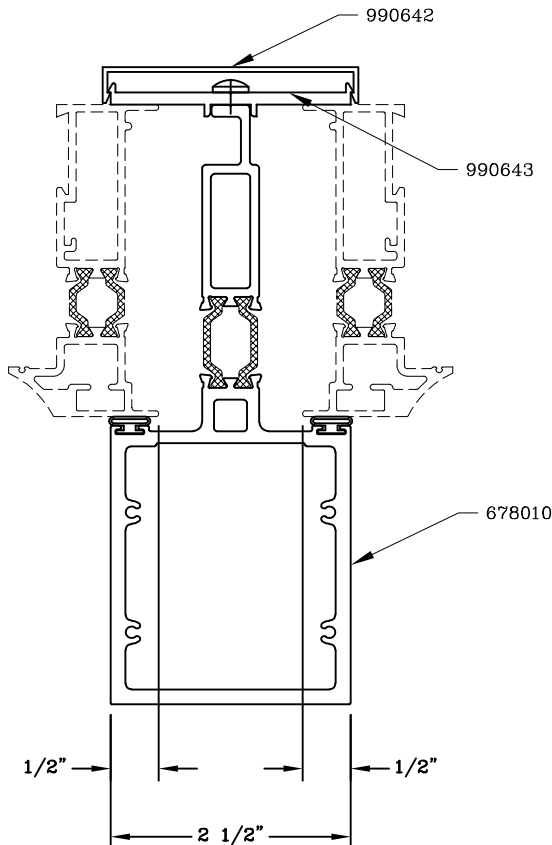

Vertical Tube Mullion - 2 1/2" Face

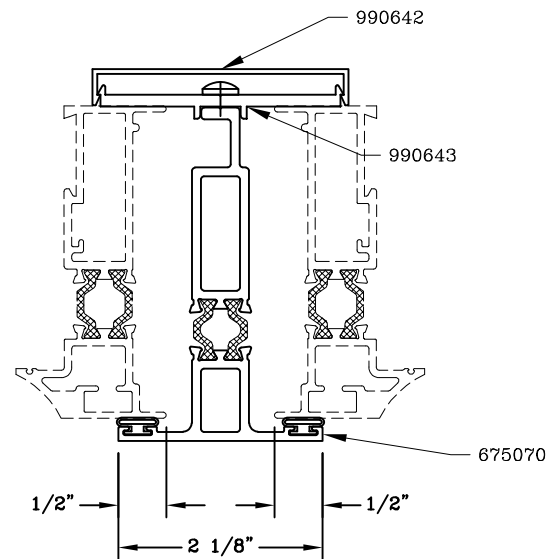

Vertical Mullion - 2 1/8" Face

Graham Architectural Products reserves the right to change, add, cancel, remove or otherwise modify the details illustrated without prior notice.

1551 Mt. Rose Avenue, York, Pennsylvania 17403-2909 717.849.8100 Toll Free: 800/755-6274

0223 - AC.03K

Web Site: www.grahamwindows.com

Accessories – 3 1/4” Products



Series: Accessories Manufacturing Code: AC03L

Drawing 1/2 Scale – For Custom Size Drawing Contact Graham

Note: Sealant Not Shown On Details. Refer To General Installation Instructions.

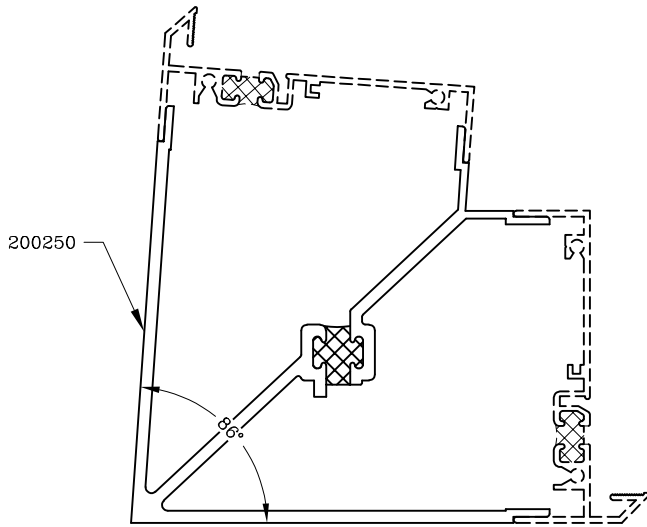

86° Corner Mullion

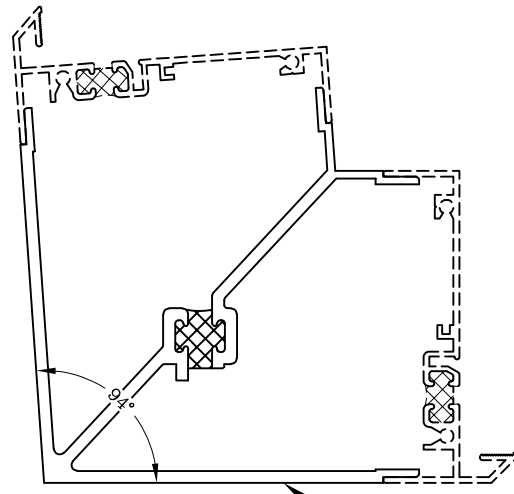

94° Corner Mullion

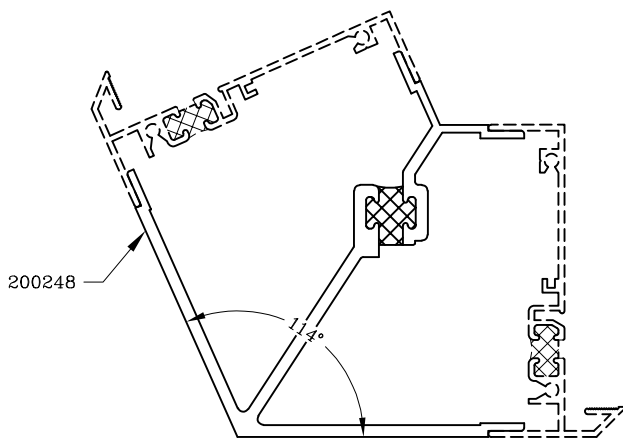

114° Corner Mullion

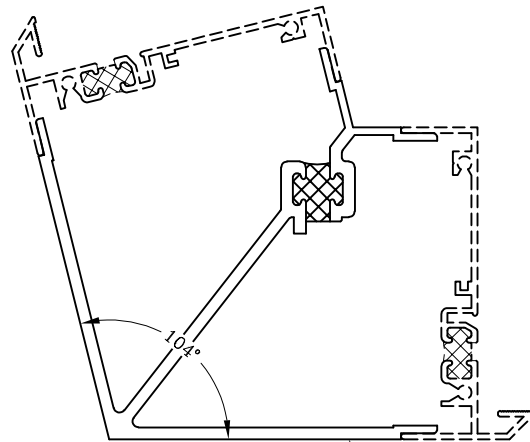

104° Corner Mullion

Graham Architectural Products reserves the right to change, add, cancel, remove or otherwise modify the details illustrated without prior notice.

1551 Mt. Rose Avenue, York, Pennsylvania 17403-2909 717.849.8100 Toll Free: 800/755-6274

0223 – AC.03L

Web Site: www.grahamwindows.com

Accessories - 3 1/4" Products



Series: Accessories Manufacturing Code: AC03M

Drawing 1/2 Scale - For Custom Size Drawing Contact Graham

Note: Sealant Not Shown On Details. Refer To General Installation Instructions.

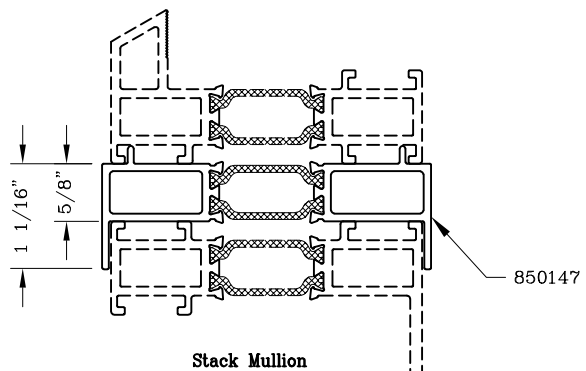
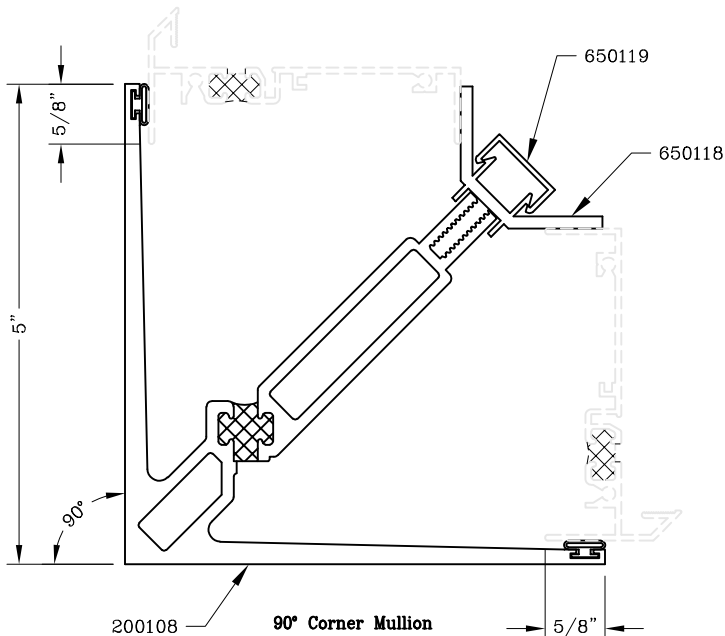
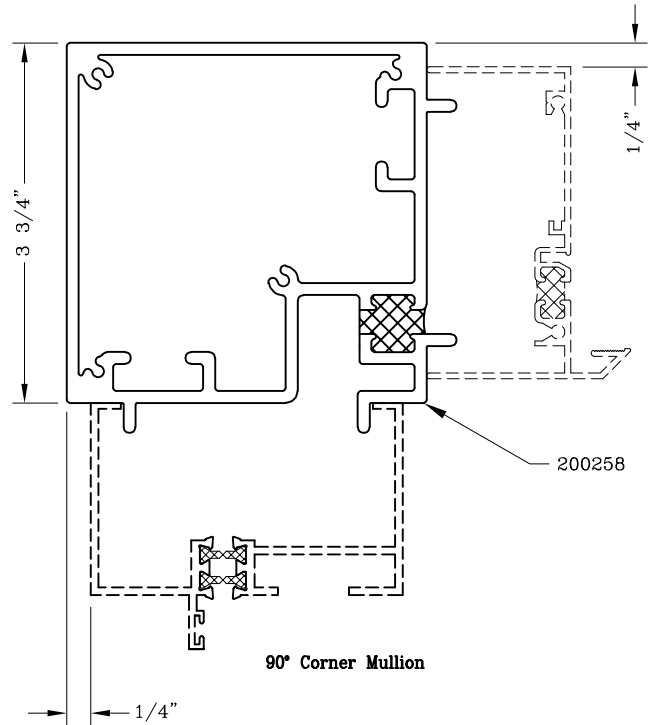
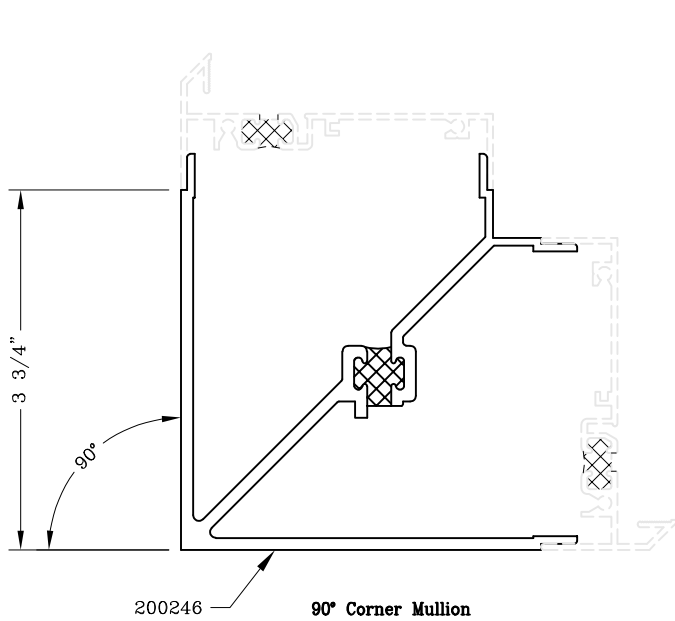

Graham Architectural Products reserves the right to change, add, cancel, remove or otherwise modify the details illustrated without prior notice.

1551 Mt. Rose Avenue, York, Pennsylvania 17403-2909 717.849.8100 Toll Free: 800/755-6274

0721 - AC.03M

Web Site: www.grahamwindows.com

Accessories - 3 1/4" Products



Series: Accessories Manufacturing Code: AC03N

Drawing 1/2 Scale - For Custom Size Drawing Contact Graham

Note: Sealant Not Shown On Details. Refer To General Installation Instructions.

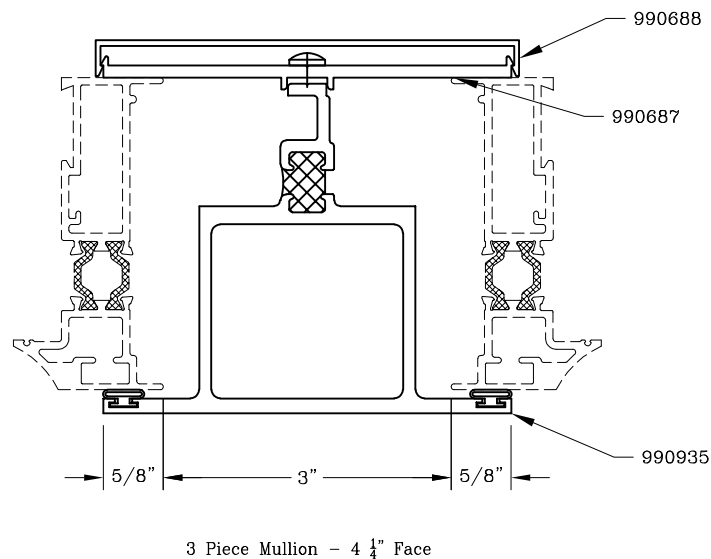
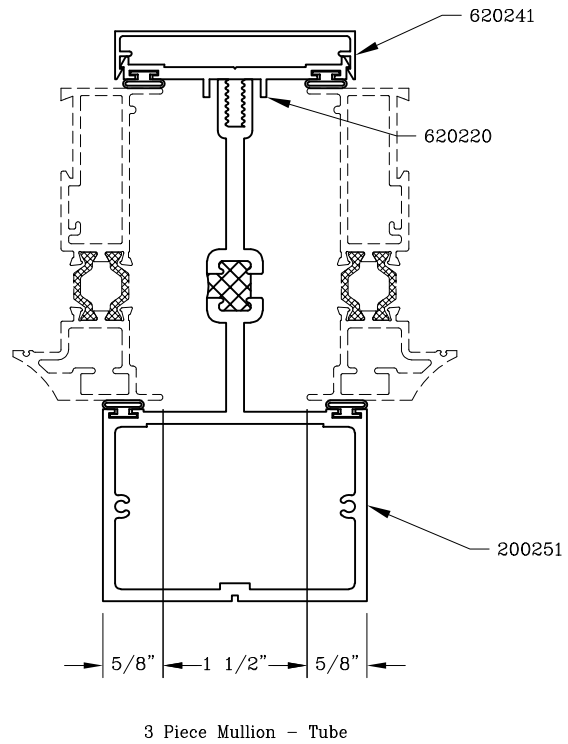
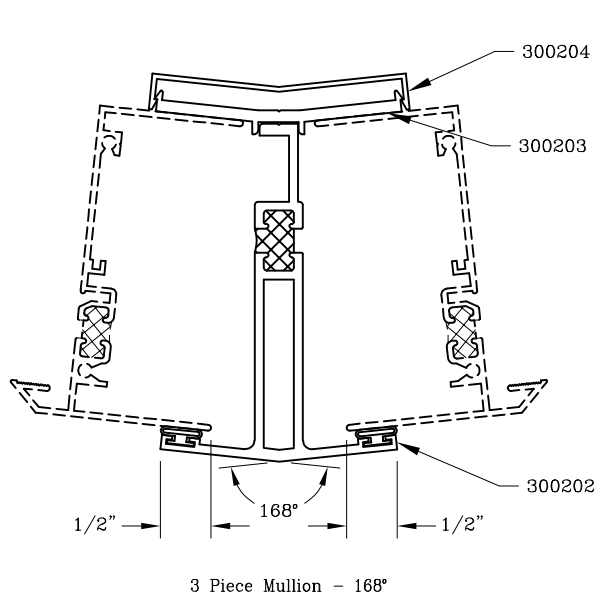

Graham Architectural Products reserves the right to change, add, cancel, remove or otherwise modify the details illustrated without prior notice.

1551 Mt. Rose Avenue, York, Pennsylvania 17403-2909 717.849.8100 Toll Free: 800/755-6274

0223 - AC.03N

Web Site: www.grahamwindows.com

Accessories – 3 1/4” Products



Series: Accessories Manufacturing Code: AC030

Drawing 1/2 Scale – For Custom Size Drawing Contact Graham

Note: Sealant Not Shown On Details. Refer To General Installation Instructions.

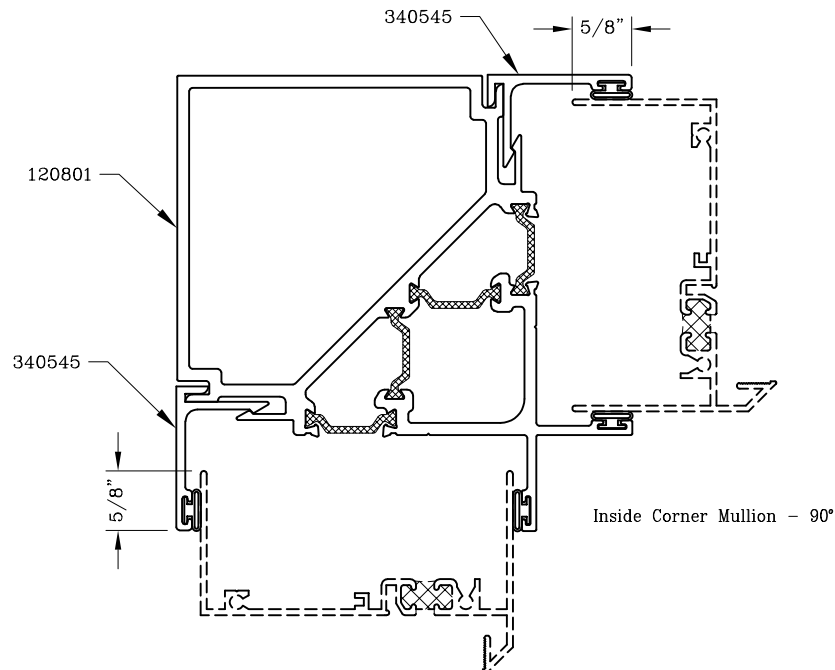
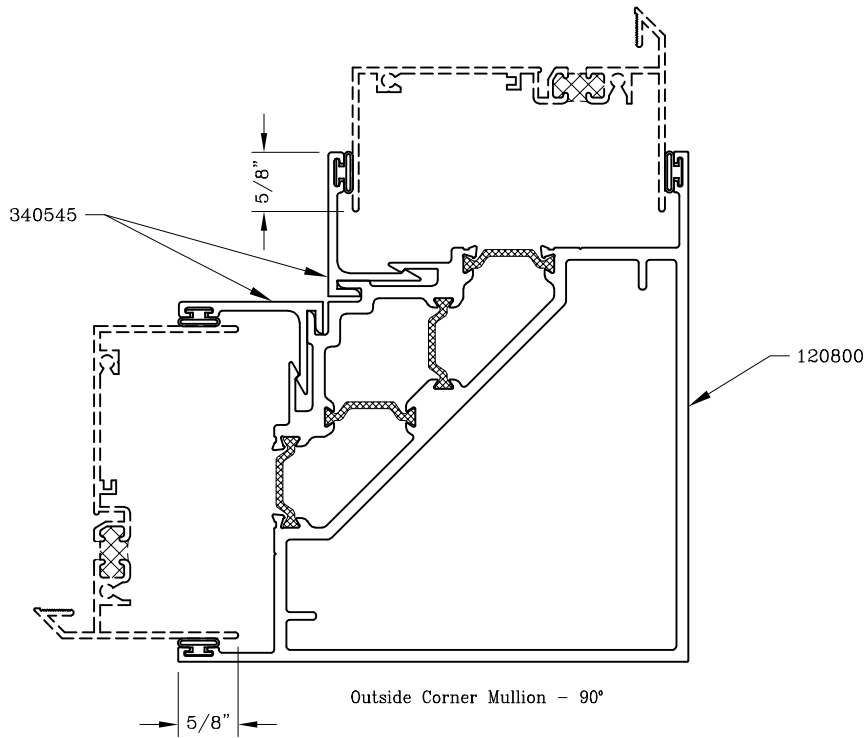

Graham Architectural Products reserves the right to change, add, cancel, remove or otherwise modify the details illustrated without prior notice.

1551 Mt. Rose Avenue, York, Pennsylvania 17403-2909 717.849.8100 Toll Free: 800/755-6274

0223 – AC.030

Web Site: www.grahamwindows.com

Accessories – GT Products 3 1/4"



Series: Accessories Manufacturing Code: GT03A

Drawing 1/2 Scale – For Custom Size Drawing Contact Graham

Note: Sealant Not Shown On Details. Refer To General Installation Instructions.

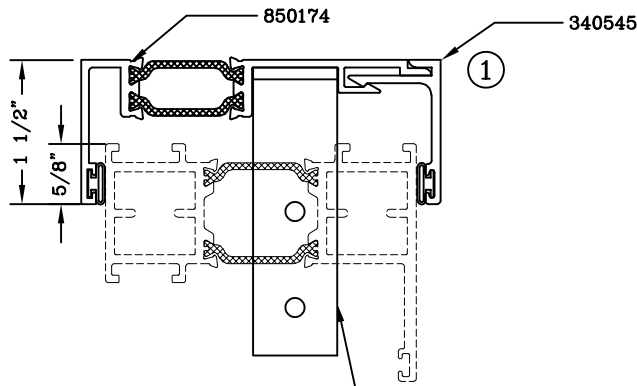

Attachment Angle for 3 pc Mullion P/N 929308
Attach with #10 M.N. Screws (By Installer)

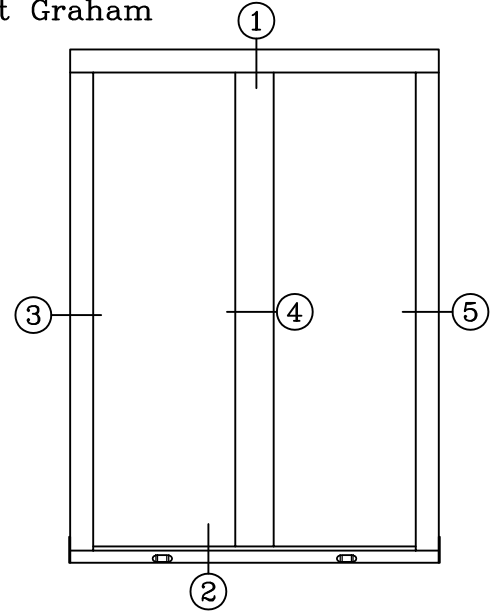

ELEVATION

