

# Blast Mitigation – 2 1/4” Interior Blast Guard Casement Inswing



Series: B6500 Manufacturing Code: B6504

Drawing 1/2 Scale – For Custom Size Drawing Contact Graham

Note: Sealant Not Shown On Details. Refer To General Installation Instructions.  
For Other Blast Pressures And GSA Levels Contact Factory

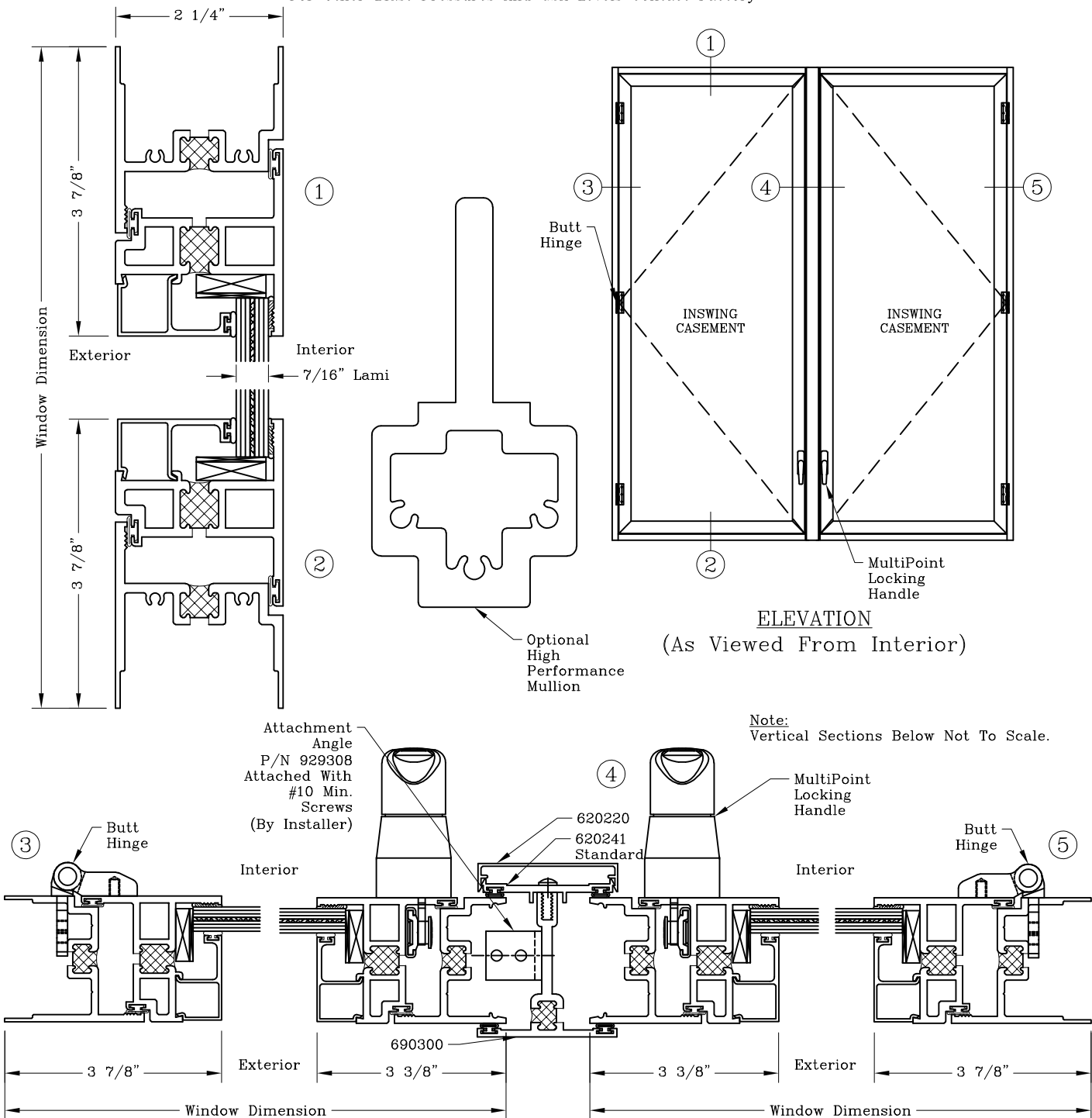

Note: Dashed Lines Represent Inswing Vented Units Solid Lines Represent  
Outswing Vented Units; Lines Converge At Hinge Side Of Vent

Graham Architectural Products reserves the right to change, add, cancel, remove or otherwise modify the details illustrated without prior notice.

1551 Mt. Rose Avenue, York, Pennsylvania 17403-2909 800/755-6274 Fax: 800/366-5097

05.21 – B65.04

Web Site: [www.grahamwindows.com](http://www.grahamwindows.com)

# Blast Mitigation – 2 1/4” Interior Blast Guard Casement Inswing



Series: B6500

Manufacturing Code: B6505

Drawing 1/2 Scale – For Custom Size Drawing Contact Graham

Note: Sealant Not Shown On Details. Consult Technical Services At Factory For Sealing Procedures.  
For Other Blast Pressures And GSA Levels Contact Factory

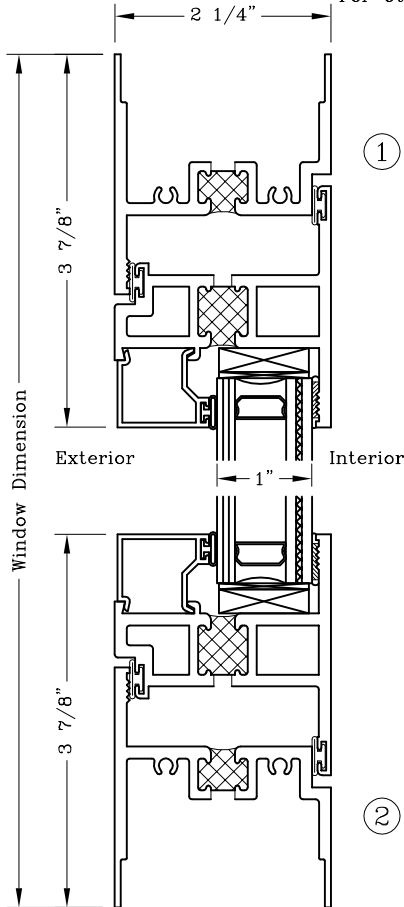

\*Note:  
Performance  
Based On  
Single Glazed  
7/16”  
Lami Unit

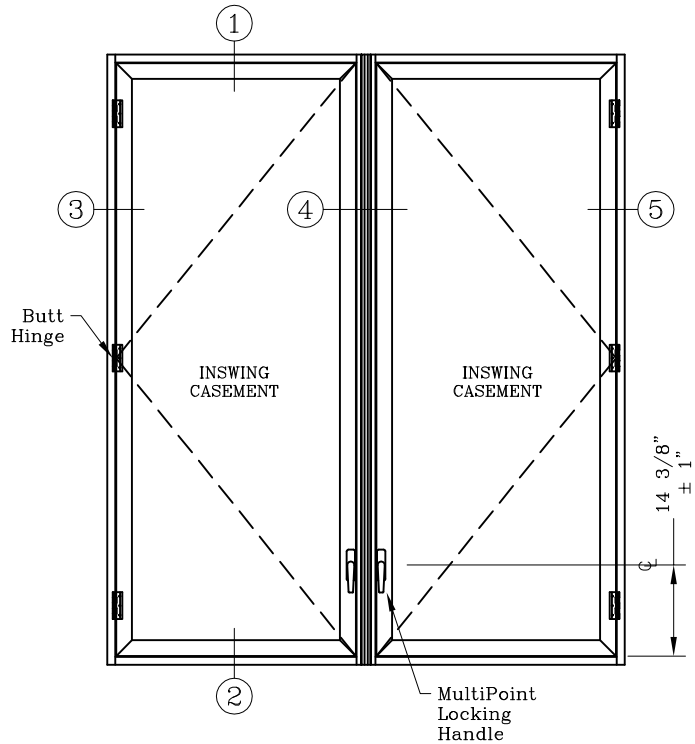

ELEVATION  
(As Viewed From Interior)

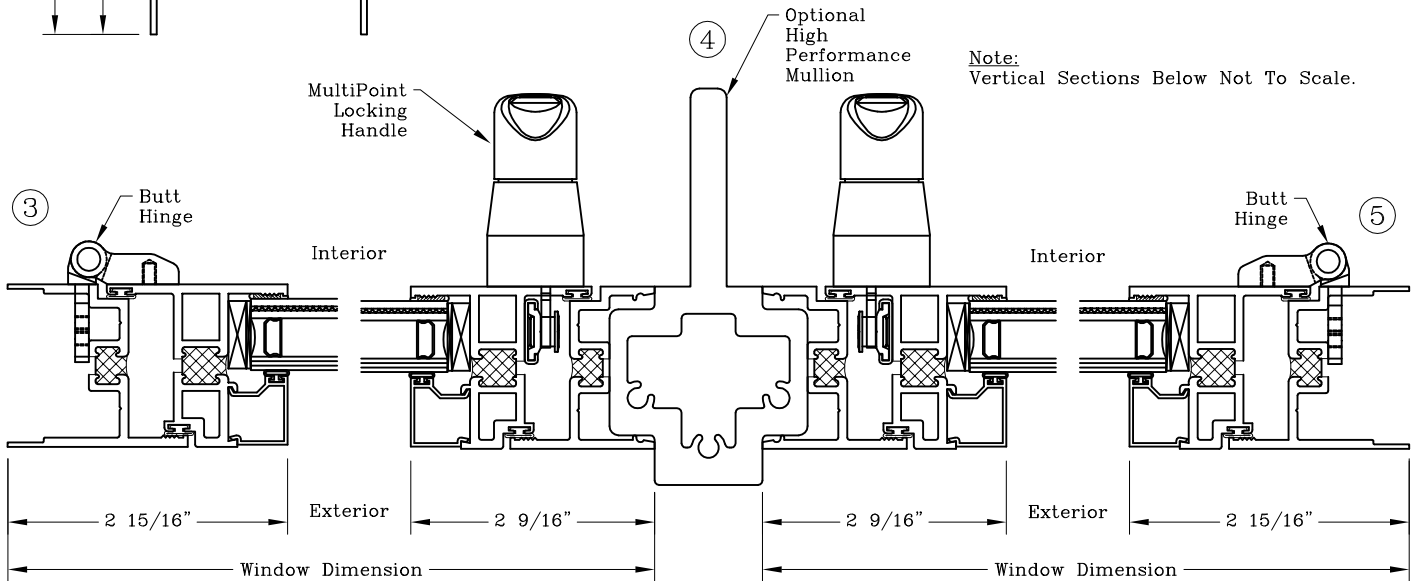

Note: Dashed Lines Represent Inswing Vented Units Solid Lines Represent  
Outswing Vented Units; Lines Converge At Hinge Side Of Vent

# Blast Mitigation – 2 1/4” Interior Blast Guard Fixed



Series: B6500

Manufacturing Code: B6506

Drawing 1/2 Scale – For Custom Size Drawing Contact Graham

Note: Sealant Not Shown On Details. Consult Technical Services At Factory For Sealing Procedures.  
For Other Blast Pressures And GSA Levels Contact Factory

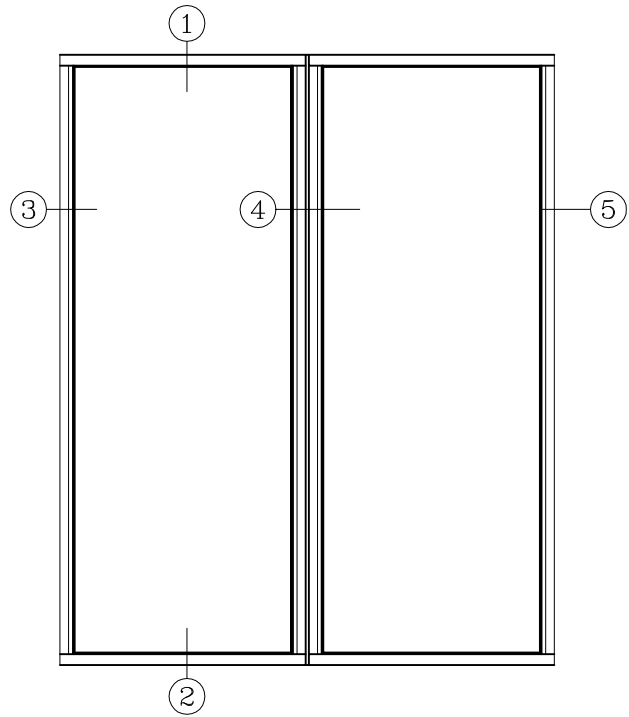
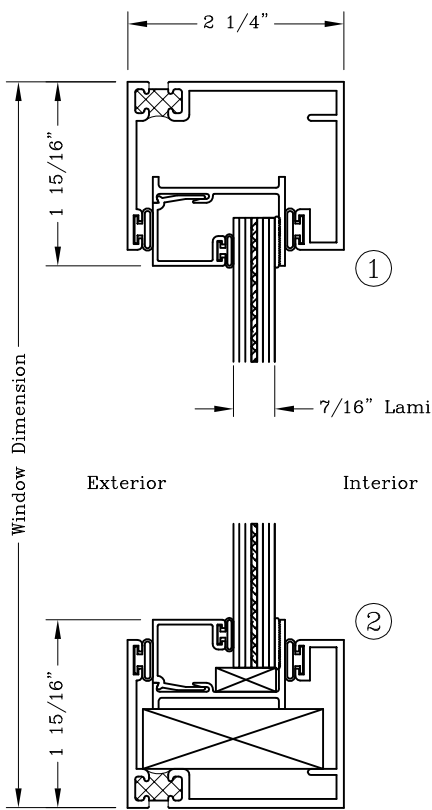

ELEVATION  
(As Viewed From Interior)

Optional High Performance Mullion

Note:  
Vertical Sections Below Not To Scale.

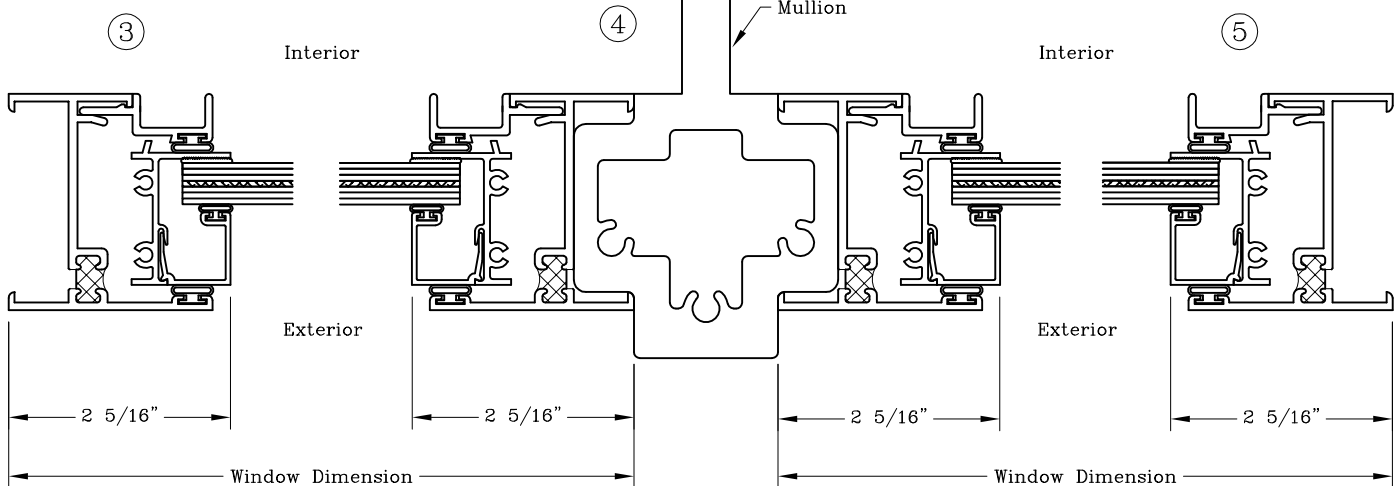

# Blast Mitigation – 2 1/4” Interior Blast Guard Fixed



Series: B6500

Manufacturing Code: B6507

Drawing 1/2 Scale – For Custom Size Drawing Contact Graham

Note: Sealant Not Shown On Details. Consult Technical Services At Factory For Sealing Procedures.  
For Other Blast Pressures And GSA Levels Contact Factory

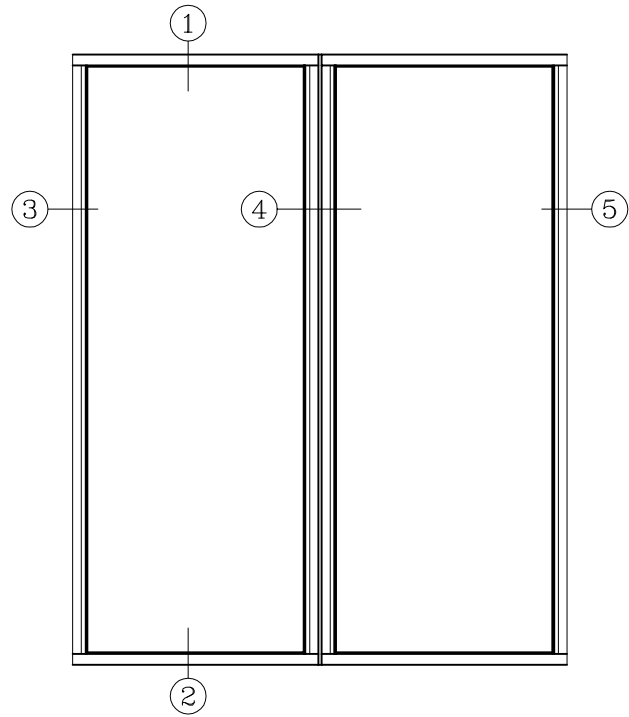
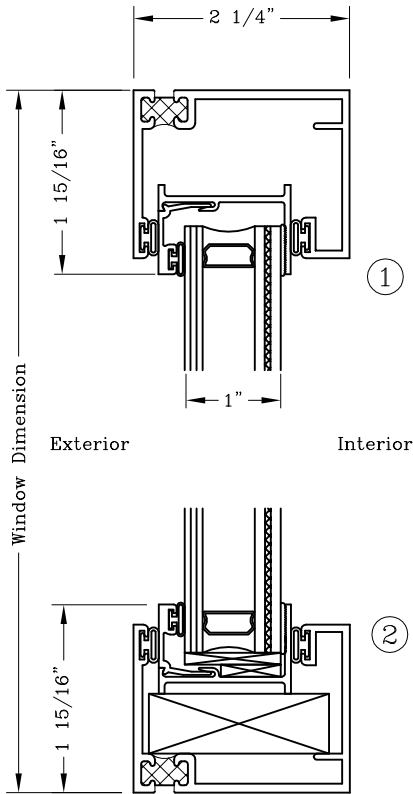

ELEVATION  
(As Viewed From Interior)

Note:  
Vertical Sections Below Not To Scale.

